

LOGSET **GT** Forwarder



SIMPLY BETTER

LOGSET

LOGSET 12F GT

BIGGEST FORWARDER IN THE LOGSET RANGE

SAFE 20-TON FORWARDER FOR TOUGH CONDITIONS

The Logset 12F GT is the biggest forwarder in the Logset range. This machine carries the highest possible timber volume. Thanks to the powerful 287 hp engine and the amplified tractive force of 250 kN, the Logset 12F GT is also the most efficient forwarder. The forwarder has improved new technology and lots of user-friendly features. The new patented deceleration assistant and protection system (DeX) allows outstanding performances in the most challenging terrain.

This forwarder embraces all the things Logset values in the machine range: reliability, low running costs and enough power to enhance the productivity without compromise.

DECELERATE ASSISTANT AND PROTECTION SYSTEM (DEX)

The DeX is an intelligent engine brake assistant that controls the forwarder in situations requiring higher engine braking moment, for example when driving downhill in steep conditions. The DeX does not only improve the safety and comfort of the driver, but also protects the engine from overspeed moment. This increases the lifetime of the engine and transmission components.

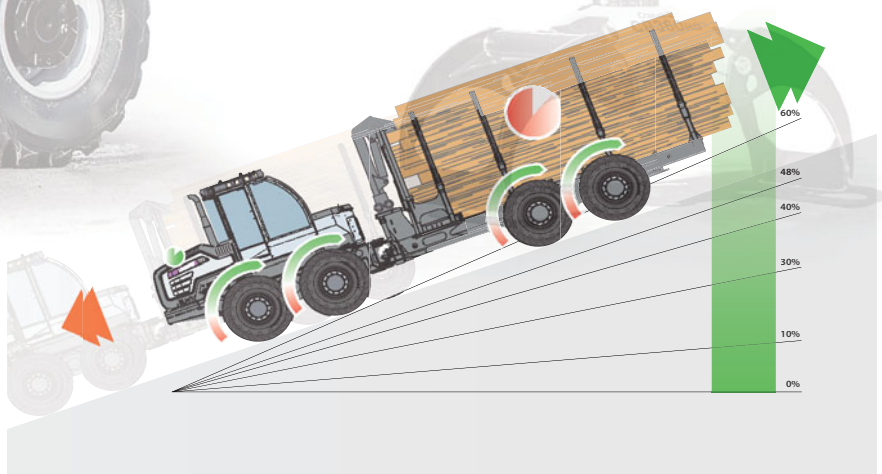

LOGSET

Advantages with the Logset 12F GT forwarder

TOTAL OPERATION AND CONTROL SYSTEM 2 (TOC 2)

The forwarder is equipped with the user-friendly Logset TOC 2 machine control system. Thanks to the control system, the operator saves a great deal of fuel and the driving experience is soft and smooth. The crane control is also fast and accurate. If the machine has several operators, they can save their personalized settings for the crane.

CABIN

The cabin offers first-class comfort and an unobstructed view when driving and loading. It is spacious and has big storage compartments. The forwarder is easy to maneuver because all the wheels are in sight.

ENGINE

The diesel engine in the Logset forwarder range has the best combination of good fuel economy and outstanding power, but it is also environmentally friendly.



FUEL TANK

With the 240-litre fuel tank capacity, the operator can extend the work shift without refueling. The correct dimensioning of the oil tank in each machine model ensures a longer lifespan of the hydraulic components.

BOGIES

The multiple disc differential lock of the strong 20 ton planetary bogie axles protects the transmission from mechanical strain. This prolongs the lifetime of the components.



CRANE

A great advantage of the Mesera crane is its boom geometry. The crane is especially designed for forwarders, and both loading and unloading is comfortable and easy. The Logset 12F GT forwarder has the strongest Mesera forwarder crane, Mesera 142, that lifts even the heaviest loads. The hoses are well protected inside the telescopic arm. A tilt base for the crane is also available for efficient and precise working in slopes.

LOAD BAY

The strong, adjustable and durable load bay carries more wood than ever before. The Logset 12F GT can be loaded with 30 solid m³ of logs.

TRACTIVE EFFORT

The Logset 12F GT has an outstanding tractive effort of 250 kN. The forwarder performs even in the most difficult terrains. It is powerful, accurate and reliable. With the help of the 28.5" tires, the forwarder carries even the heaviest loads.

DECELERATE ASSISTANT AND PROTECTION SYSTEM (DeX)

The patented deceleration assistant and protection system assists and safeguards the operator and the forwarder. This new solution enables a safer and easier operating of the Logset 12F GT forwarder in steep terrains.



Technical data



MODEL

12F GT

DIMENSIONS

Own weight from, kg	24 000 (52 900 lbs)
Load capacity, kg	20 000 (44 100 lbs)
Load area length, m	5.4/6.1 (213/240 in)

ENGINE

Type	AGCO Power 74 LFTN
Stage	EU Stage V
Power at 1900 rpm, kW	211 (287 hp)
Torque at 1500 rpm, Nm	1 280 (944 ft lb)
Fuel tank, l	240 (63 US gal)
DEF tank, l	30 (7.9 US gal)

TRANSMISSION

Type	Hydrostatic mechanical
Tractive effort, kN	250 (56 200 lbf)
Gear box	2 gears

HYDRAULIC SYSTEM

Pump size, cm ³	180
Pressure, MPa	24 (3 481 psi)
Oil tank, l	175 (46 US gal)

CABIN

Control system: TOC 2 • Battery voltage: 24 V • Safety tested and approved cabin

WHEELS

Tyres	780/50-28.5
-------	-------------

CRANE OPTIONS

Crane	Mesera 142
Lifting capacity, kNm	178 (131 290 ft lb)
Reach options, m	8.1/10 (27/33 ft)
Rotator, °	360

OPTIONAL EQUIPMENT

Smooth Ride cabin suspension • Bulldozer blade • Diesel heater • Crane tilt • Contact your local dealer for more information about other options

LOGSET 12F GT

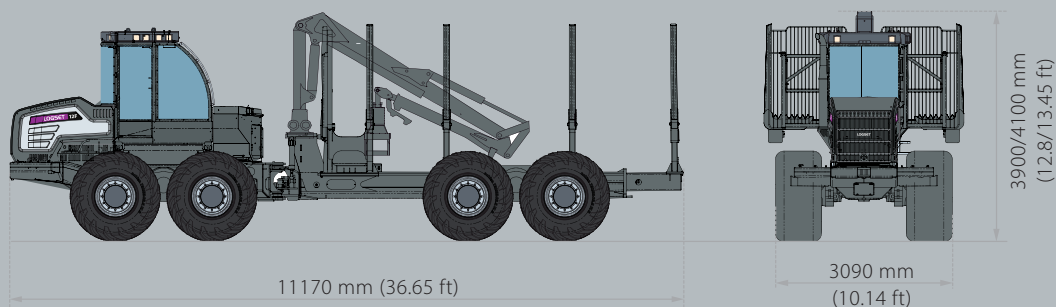

SIMPLY BETTER

LOGSET



Forwarder range 01/22 - EN

We reserve the right to make changes without prior notice.

All technical specifications are for guidance only.

The pictures and diagrams do not always show standard versions of the machines.

Copyright Logset Oy.



LOGSET Oy
Hännisentie 2
FI-66530 Koivulahti
FINLAND
Tel. +358 10 286 3200

LOGSET
SIMPLY BETTER

www.logset.com