

# LOGSET **GT** Forwarder



5FP GT

SIMPLY BETTER

**LOGSET**

# LOGSET 5FP GT

## PREMIUM VERSION OF THE LOGSET 5F GT WITH ADDED POWER

Logset 5FP GT is a versatile forwarder. It is compact and a nimble for thinning operations, but has enough power for clear felling operations. It is a 12 ton forwarder with a strong transmission and oversized components for its class. The 6-cylinder 7,4 liter AGCO Power engine has enough torque in all situations, but with a low fuel consumption. The forwarder maintains the desired driving speed also in demanding conditions. It is reliable and it does not require a lot of spare parts. Thanks to these features, it is a forwarder with high capacity and exceptionally low running costs.

A high production requires also the best possible ergonomics. The cabin has efficient noise insulation and the large windows offer excellent visibility in all directions. The user friendly TOC 2 control system gives a good precision both for crane and transmission. The operator can work fast and efficient without strain. The automatic cruise control allows the driving speed to be easily adjusted with a potentiometer. The constant driving speed facilitates the operator's work and results in lower fuel consumption. Easy access for service jobs and a big fuel tank minimize the service interruptions.

**LOGSET**

# Eight advantages with the Logset forwarder

## ENGINE

The diesel engine in the Logset forwarder range has the best combination of good fuel economy and outstanding power, but it is also environmentally friendly.

## CABIN

The cabin offers first-class comfort and an unobstructed view both when driving and loading. It is spacious and has big storage compartments. The forwarder is easy to maneuver because the wheels are in sight.



## FUEL AND HYDRAULIC TANKS

Thanks to the 200-liter fuel tank capacity, the operator can extend the work shift without refueling. The correct dimensioning of the oil tank in each machine model ensures a longer lifespan of the hydraulic components.

## BOGIES

The machine is available with or without balancing on the NAF bogies, depending on the needs.

## CRANE

A great advantage of the Mesera crane is its boom geometry. The crane is especially designed for forwarders, and both loading and unloading is comfortable and easy. The model 83 has reaches from 7,2 meters to 10 meters, and it comes with integrated hoses.

## TOTAL OPERATION AND CONTROL SYSTEM 2 (TOC 2)

The forwarder is equipped with the user-friendly TOC 2 machine control system. Thanks to the control system, the operator saves a great deal of fuel and the driving experience is soft and smooth. The crane control is also fast and accurate. If the machine has several operators, they can save their personalized settings for the crane.



## TRACTIVE EFFORT

The hydrostatic transmission gives the best performance even in the most difficult terrains. It is powerful, accurate and reliable.

## LOAD BAY

The strong, adjustable and durable load bay carries more wood than ever before. The Logset 5FP GT has a variable load bay length ranging from 4.3 meters to over 5 meters.



# Technical data



MODEL		5FP GT
<b>DIMENSIONS</b>		
Own weight from, kg		16 500 (36 400 lbs)
Load capacity, kg		12 000 (26 500 lbs)
Load area length, m		4.4/5 (173/196.85 in)
<b>ENGINE</b>		
Type		AGCO Power 74 AWF
Stage		EU Stage IV / EPA Tier 4 final
Power at 1900 rpm, kW		170 (230 hp)
Torque at 1500 rpm, Nm		950 (701 ft lb)
Fuel tank, l		205 (54 US gal)
DEF tank, l		30 (7.9 US gal)
<b>TRANSMISSION</b>		
Type		Hydrostatic mechanical
Tractive effort, kN		169 (38 000 lbf)
Gear box		2 gears
<b>HYDRAULIC SYSTEM</b>		
Pump size, cm <sup>3</sup>		140
Pressure, MPa		23 (3 336 psi)
Oil tank, l		175 (46 US gal)
<b>CABIN</b>		
Control system: TOC 2 • Battery voltage: 24 V • Safety tested and approved cabin		
<b>WHEELS</b>		
Tyres		710/45-26.5
<b>CRANE OPTIONS</b>		
Crane		Mesera 83
Lifting capacity, kNm		106 (78 180 ft lb)
Reach options, m		7.2/8.5/10 (23/27/32 ft)
Rotator, °		360
<b>OPTIONAL EQUIPMENT</b>		

Bulldozer blade • Diesel heater • Crane tilt • Contact your local dealer for more information about other options

## LOGSET 5FP GT

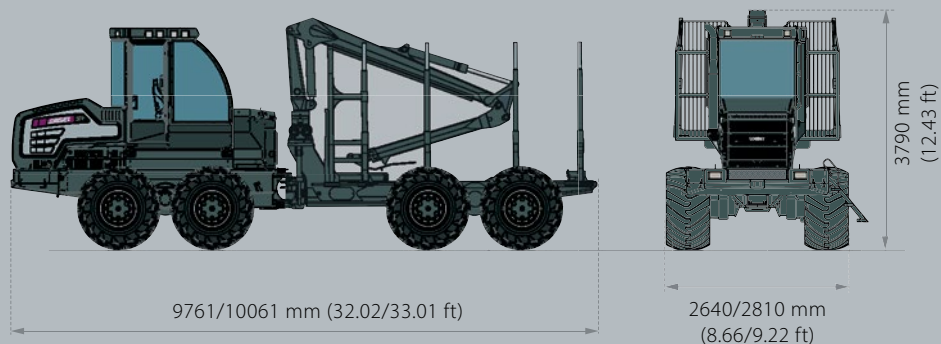

SIMPLY BETTER

**LOGSET**



Forwarder range 01/22 - EN

We reserve the right to make changes without prior notice.

All technical specifications are for guidance only.

The pictures and diagrams do not always show standard versions of the machines.

Copyright Logset Oy.



**LOGSET Oy**  
Hännisentie 2  
FI-66530 Koivulahti  
FINLAND  
Tel. +358 10 286 3200

**LOGSET**  
SIMPLY BETTER

[www.logset.com](http://www.logset.com)