

Material Handling Machine

LH 80 Industry

Litronic®



Generation

6

Operating Weight

66,500 – 112,500 kg*

Engine

230 kW/313 HP

Stage V

Stage IIIA (compliant)

System Performance

437 kW

* Without attachment

LIEBHERR

Performance

Power Plus Speed –
Redefined Performance

Economy

Good Investment –
Savings for Long-Term

LH 80 M Industry Litronic

Operating Weight

71,500 – 76,500 kg*

Engine

230 kW/313 HP

Stage V

Stage IIIA (compliant)

System Performance

437 kW

LH 80 C Industry Litronic

Operating Weight

66,500 – 80,000 kg*

Engine

230 kW/313 HP

Stage V

Stage IIIA (compliant)

System Performance

437 kW

LH 80 M High Rise Industry Litronic

Operating Weight

86,500 – 91,800 kg*

Engine

230 kW/313 HP

Stage V

Stage IIIA (compliant)

System Performance

437 kW

LH 80 C High Rise Industry Litronic

Operating Weight

87,800 – 95,000 kg*

Engine

230 kW/313 HP

Stage V

Stage IIIA (compliant)

System Performance

437 kW

LH 80 C Gantry Industry Litronic

Operating Weight

107,200 – 112,500 kg*

Engine

230 kW/313 HP

Stage V

Stage IIIA (compliant)

System Performance

437 kW

* Without attachment



Reliability

Durability and Sustainability –
Quality Down to the Last Detail

Comfort

Perfection at a Glance –
When Technology is Comfortable

Maintainability

Efficiency Bonus – Even with
Maintenance and Service



Performance



Power Plus Speed – Redefined Performance

Liebherr has been designing and manufacturing market leading material handling machines for over 50 years. With the different versions of the LH 80 Industry machine model of the new generation of Liebherr handlers, high performance and yet economical machines specially designed for use in scrap recycling, timber yards and for handling of bulk materials.

Maximum Handling Capacity

New Power Unit

The LH 80 Industry material handling machine features a powerful Liebherr 6-cylinder in-line engine with constant 230 kW and 12.0 l displacement. This guarantees the high performance level of the machine and at the same time reduces fuel consumption.

High Swing Torque

The separate hydraulic pump in the closed slewing circuit only supplies hydraulic fluid to the swing mechanism. The maximum delivery volume is thus available at any time for turning the uppercarriage for fast and dynamic rotational movements.

Energy Recovery System ERC

The energy saved by lowering of the equipment in the ERC system is also available to the machine for the engine power, the resulting system performance for the material handling machine LH 80 is 437 kW. The result is more powerful, faster and more homogeneous operating cycles, which lead to increased handling capacity.

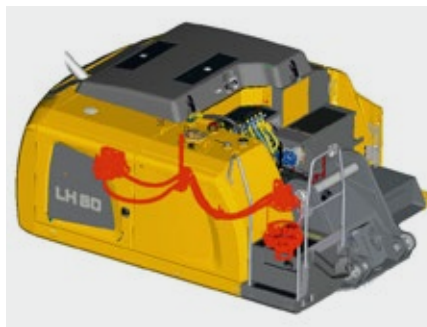

Precision Operation

LSC Hydraulic System with Electrical Pilot Control

The new 2-circuit Liebherr-Synchron-Comfort-system (LSC) with LUDV technology (flow distribution independent of load pressure) ensures faster working movements with up to 20 % less fuel consumption in comparison to the predecessor models. All work functions of the machine are controlled electrically, whereby the signals of the transmitters are only converted directly at the control block by hydraulic means. This technology enables end position damping of the equipment in order to protect the components and thus extend their service life. Simple, individual setting and adjustment of the working speed of boom, stick and slewing mechanism allow the driver to adjust the machine to each application and fully utilise the machine's capacity.

Firm and Stable Positioning

An essential prerequisite for precise working and maximum handling capacity is the firm and stable positioning of the machine. The design of the Liebherr undercarriage optimises the way forces are induced on components to minimise stress and guarantee maximum stability and durability.

Liebherr Diesel Engine

- Powerful, robust and reliable
- Maximum torque even at low speeds to ensure fast movements with low fuel consumption
- Common-Rail injection system for maximum efficiency
- Emissions treatment with Liebherr SCRFilter technology at stage V

Closed Slewing Circuit

- High torque for maximum acceleration and fast rotary movements
- Integrated speed sensor for controlling and monitoring braking movement for greater safety
- Greater fuel efficiency thanks to intelligent energy management in the closed system

Electrical Pilot Control

- Precision control irrespective of the ambient temperature for maximum precision
- Simpler and faster fault diagnostics for optimal availability
- Up to 5 individual driver profiles can be saved

Economy



Good Investment – Savings for the Long-Term

Liebherr material handling machines combine high productivity with excellent economy – all as standard. Liebherr manages to achieve this difficult goal through sophisticated engine technology from its own production and improved demand-controlled hydraulics.

Fuel Efficiency

Engine Idling and Engine Shut-down

The standard automatic idling function reduces the engine speed to idle as soon as the operator takes their hand from the joystick so that no hydraulic function is activated. Proximity sensors in the joystick levers restore the original engine speed as soon as the operator's hand is moved towards the lever again. This ensures that the set engine speed is available immediately. The result is a combination of fuel saving and reduced noise levels. Operating costs can be reduced even further with the optional automatic engine shut-down function.

Closed Hydraulic Circuit for the Swing Mechanism

The closed slewing circuit feeds the braking energy back into the system when the uppercarriage is braked. Here, new standards are set in terms of efficiency and economy. Simple yet effective.

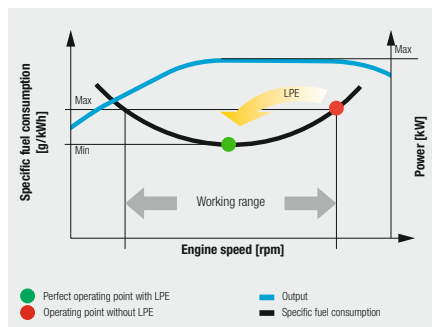

Increased Productivity

Energy Recovery System ERC

The ERC system not only brings about an enormous increase in performance and a higher handling capacity, but it also generates fuel savings of up to 30%, lower operating costs, as well as reduced pollutant and noise emissions.

Efficient Management

LiDAT, Liebherr's own data transmission and positioning system, facilitates efficient management, monitoring and control of the entire fleet park in terms of machinery data recording, data analysis, fleet park management and service. All of the important machinery data can be viewed at any time in a web browser. LiDAT offers you comprehensive work deployment documentation, greater availability thanks to shorter downtimes, faster support from the manufacturer, quicker detection of strain/overload and subsequently a longer service life of the machine as well as greater planning efficiency in your company. This service includes 1 year of use without charge as standard for the material handler LH 80.

Low Fuel Consumption Thanks to Intelligent Machine Control

- Liebherr-Power Efficiency (LPE) optimises the interaction of the drive components in terms of efficiency
- LPE enables machine operation in the area of the lowest specific fuel use for less consumption and greater efficiency with the same performance

Liebherr Attachments

- Robust and service-friendly slewing drive, can be turned 360°
- Optimum filling and clamping performance for effective material handling
- Finite element method (FEM) optimised for a perfect relationship between grapple weight, volume and a very long service life

ERC System

- Increased total power
- Higher handling capacity
- Fuel savings of up to 30%
- Lower running costs
- Reduced pollutant and noise emissions

Reliability



Durability and Sustainability – Quality Down to the Last Detail

Every day Liebherr material handlers demonstrate their qualities in a range of industrial applications all over the world. Years of experience, continuous development and the latest technologies provide maximum safety in use. Their robust design and the use of components produced in-house ensure that the LH 80 is designed for a long service life.

More Safety

Pipe Fracture Safety Valves

The standard pipe fracture safety valves on the stick and hoist cylinders prevent the equipment from dropping in an unregulated way and ensure maximum safety during every operation.

Working Range Limiters

For operations in which the working range should be limited, the material handling machines can be specified with an optional working range limitation feature. Height, depth, width and proximity settings can be set to ensure that collisions and resulting component damage are avoided.

Overload Warning Device and Load Torque Limitation

The audible and visual overload warning system continuously tells the operator about the current load situation of the machine. Furthermore, load torque limitation automatically regulates the speed of the working hydraulics to allow the maximum load bearing capacity to be approached safely. In the event of an overload, the functions which could cause the machine to topple are disabled. Only movements back to the safe working range are then possible.



High Machine Availability

Quality and Competence

Our experience, understanding of customer needs and the technical implementation of these findings guarantee the success of the product. For decades, Liebherr has been inspirational with its depth of production and system solutions. Key components such as the diesel engine, electronic components, slew ring, swivel drive and hydraulic cylinders are developed and produced by Liebherr itself. The great extent of in-house manufacturing guarantees maximum quality and ensures that components are optimally configured to each other.

Robust Design

All steel components are designed and manufactured by Liebherr itself. High-strength steel plates configured for the toughest of requirements result in high torsional stiffness and optimum absorption of forces induced for a longer service life.

Intelligent Self Diagnostics

The innovative control electronics permanently monitor the vital functions of the machine to guarantee a high level of machine availability. Components which are critical for safety have a secondary redundancy feature to guarantee maximum safety and reliability.

QPDM – Quality and Process Data Management

- QPDM allows production data to be logged, documented and evaluated
- Test specifications and machine documented automatically logged
- Ability to handle large quantities of data while maintaining uniform high quality

Piston Rod Protection

- Maximum protection of piston rod
- Robust construction of hot-dip galvanised steel for a long service life in tough applications
- Available for outriggers, hoist cylinders, ERC cylinder and tip cylinder as an option

Equipment

- Components enhanced using FEM for maximum service life even if subjected to heavy lateral stresses during demanding tasks
- Cables routed internally to protect them from damage
- High load capacities with long reaches
- Reaches over 22 m

Comfort



Perfection at a Glance – When Technology is Comfortable

The newly designed operator's work station sets new standards in comfort. The Liebherr deluxe cab is spacious, has an ergonomic design and is very quiet. This ensures that the operator remains intent and fully concentrated throughout the working day and enables him to deliver a constantly high performance.

Deluxe Cab

Ergonomic Design

The modern cab design provides excellent conditions for healthy, focussed and productive work in maximum comfort. The colour touchscreen display, the controls and operator's comfort seat are all coordinated to form a perfect ergonomic unit. In addition the ergonomic joysticks allow the machine operation to be both pleasant and precise.

Excellent All-round Vision

The large areas of glass, different versions of cab elevations and the rear and side area monitoring systems provide the operator with an excellent view of their working area and the zone around the machine. This perfect view enhances the operator's safety and ensures that they can handle the machine safely at all times.

Low Noise Levels

The use of viscoelastic mounts, good insulation and low-noise diesel engines from Liebherr minimises noise emissions and vibrations. The noise levels are just 70 dB(A) in the operator's cab and 105 dB(A) outside. This means that the material handler LH 80 has low noise to preserve people and the environment.



Comfortable Operation

Proportional Control

Precision control of the material handling machine is especially important in applications such as scrap recycling or when handling bulk material. Thanks to the standard proportional control, even such demanding operations can be mastered in style.

Joystick Steering and Stabilizing

The standard joystick steering gives the operator an additional comfort boost. The steering movement can be conveniently executed using the joystick, eliminating the need to reposition during the work cycle. Substituting the steering wheel in favour of joystick steering provides additional leg-room and a clear view of the working area. A new standard feature is Joystick control of the outriggers for more convenience and an increased productivity.

Colour Touchscreen Display and Operation Unit

The 7" colour touchscreen display is intuitive in its operation and provides continuous information about all important operating data. The shortcut keys can be individually assigned and are selected quickly and easily with the menu strip.

Safe Access

- Foldable left arm console, as well as wide, non-slip steps, catwalks and platforms, and ergonomically positioned handles for an easy and safe access
- All access systems are designed to national guidelines and statutory regulations
- Sliding door for comfortable entry with narrow platforms is available as an option

Operator's Seat Comfort with Adjustable Armrests

- Greater seating comfort due to variable damper hardness, lockable horizontal suspension, pneumatic lumbar support, seat heating and passive seat air conditioning for concentrated working
- Individual adjustment options for armrests, seat cushion depth, seat angle and head restraint for comfortable working

Joystick with Proportional Control

- Good functionality with streamlined, ergonomic design
- 4-way mini joystick can be used to control all operations e.g. steering, outriggers and attachments etc.
- Joysticks – each with two newly designed buttons and a rocker switch – increase the number of functions available

Maintainability



Efficiency Bonus – Even with Maintenance and Service

The Liebherr LH 80 material handling machine is powerful, robust, precise and efficient. It also features integral maintenance benefits as a result of their service-based machine design. The maintenance work for the Liebherr material handler can be carried out quickly, easily and safely. This minimises machine's maintenance costs and downtime.

Efficient Maintenance Concept

Service-Based Machine Design

The service-based machine design guarantees short servicing times, thus minimising maintenance costs due to the time it saves. All the maintenance points are easily accessible on catwalks and platforms, and easy to reach due to the large, wide-opening service doors. The enhanced service concept places the maintenance points close to each other and reduces their number to a minimum. This means that service work can be completed even more quickly and efficiently.

Integral Maintenance Benefits

Maintenance work helps to keep the machine fully functional. However this kind of work leads to machine downtimes which must be minimised. With change intervals of up to 2,000 hours for engine oil and up to 8,000 hours for hydraulic oil, Liebherr has significantly reduced the amount of maintenance and increased the productivity of the material handlers. In addition, central lubrication systems minimise daily maintenance.



Lubrication as it Works

- Fully automatic central lubrication system for uppercarriage and equipment
- Fully automatic central lubrication system for the undercarriage and attachments available as an option
- Lubricates without interrupting work to ensure better productivity and a long component service life

Excellent Service Access

- Large, wide-opening service doors
- Engine oil, fuel, air and cab air filters are easily and safely accessible on catwalks and platforms
- The oil level in the hydraulic tank can be checked from the cab
- Short service times for more productivity

SCRFilter for Stage V

- The SCR filter system developed by Liebherr includes a DOC catalyst, an SCR catalyst and an SCR-coated particulate filter
- The DOC catalyst requires no maintenance and the coated particulate filter is regenerated passively
- The maintenance intervals can be extended to more than 4,500 operating hours

Your Competent Service Partner

Remanufacturing

The Liebherr remanufacturing program offers cost-effective reconditioning of components to the highest quality standards. Various reconditioning levels are available: Replacement components, general overhaul or repair. The customer receives components with original part quality at a reduced cost.

Competent Advice and Service

Competent advice is a given at Liebherr. Experienced specialists provide decision guidance for your specific requirements: application-oriented sales support, service agreements, economical repair alternatives, original parts management, as well as remote data transmission for machine planning and fleet management.

Fast Spare Parts Service

The Liebherr spare parts service provides 24-hour delivery and is therefore available to our dealers around the clock. Thanks to the electronic spare parts catalogue, the parts can be selected and ordered quickly and reliably using the Liebherr online portal. Your order can be tracked at any time using the online tracking system.

Material Handling Machine Overview

Equipment

- High load capacities and long reaches thanks to optimised kinematic properties and robust construction for greater handling performance
- Energy recovery cylinder filled with nitrogen for maximum efficiency through less fuel consumption at more handling capacity
- Pipe fracture safety valves on hoist and stick cylinders and retract stick shut-off for maximum safety during every application
- Electro-hydraulic end position control extends the service life of the components
- Quick coupling systems and attachments made by Liebherr for maximum machine capacity utilisation and greater handling performance

Operator's Cab

- Joystick steering without steering column as standard for convenient operation, greater legroom and clear view of the working area
- Less strain on the operator, workers and reduced environmental pollution due to lower noise emissions
- Optimum visibility thanks to large glass surfaces and standard rear and side area monitoring with camera
- Proportional control as standard with 4-way mini joystick for greater precision, high precision control and functions





Uppercarriage

- 2-circuit Liebherr-Synchron-Comfortsystem (LSC) with LUDV technology for faster working speed at up to 20% less fuel consumption
- 230 kW engine output and greater pump flow for fast work cycles, convincing dynamics and maximum handling performance
- Electrical pilot control enables individual settings for the operator and new options such as load torque limitation
- Reduction in operating costs thanks to built-in maintenance advantages and optimum service accessibility

Undercarriage

- Optimised hydraulics with closed slewing mechanism circuit for greater fuel efficiency and faster work cycles
- Central lubrication system (manual / full automatic) for more productive working time (optional available)
- Load-holding valves fitted as standard on all support cylinders for maximum stability in every application
- Low service costs thanks to travel drive without gearbox and cardan shafts

The Perfect Solution for Every Application

Attachments

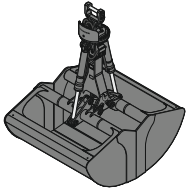

Shells for loose material



Multi-tine grab



Wood grab

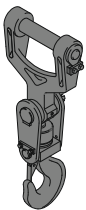

Load hook

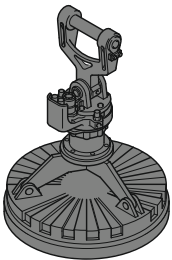

Magnet devices

Sticks

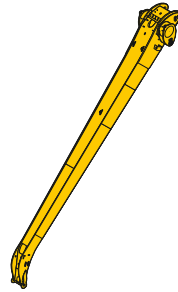

Angled stick

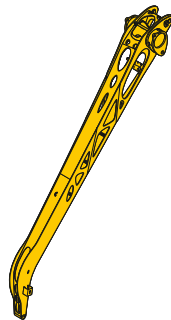

Lightweight stick

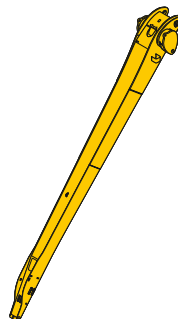

Straight stick

Booms

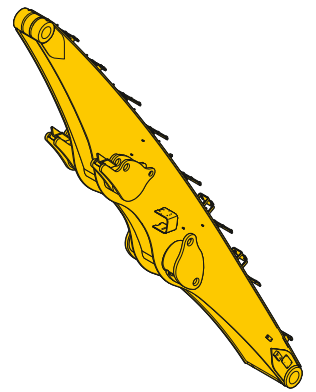

Straight boom

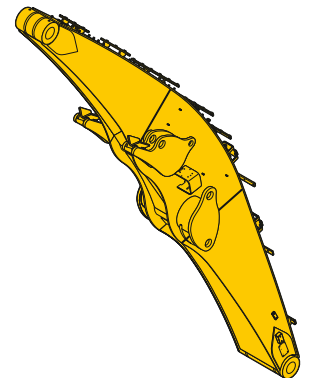

Angled boom

Cab Elevations

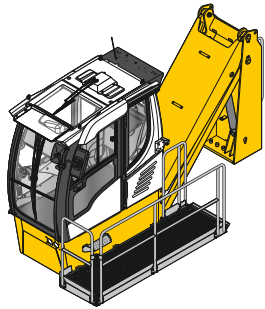

Hydraulic cab elevation

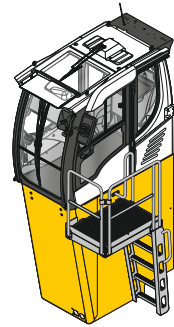

Rigid cab elevation

Uppercarriage

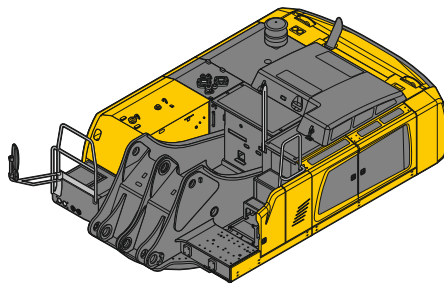

Turret Elevations



Undercarriage

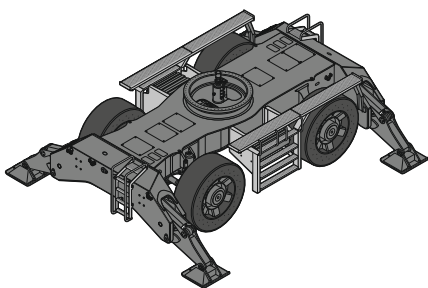

Mobile

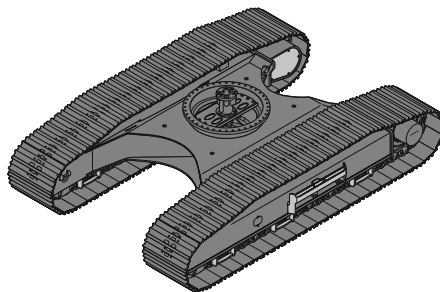

Crawler

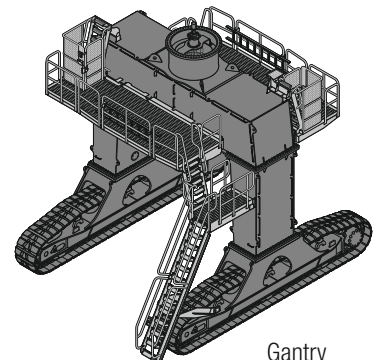

Gantry

Experience the Progress

The invention of the mobile tower crane in 1949 also marked the birth of the Liebherr company. During its first decade the small construction company developed into an established manufacturer of construction machines and other technically advanced products. The R 353 and its first industrial equipment were launched in 1951 to lay the foundations for the production of today's material handling machines. The A 911

mobile material handling machine a few years later enabled the company to make the breakthrough into material handling. Over the years the machines have been developed continually and today they are designed uncompromisingly for the industrial use.

1949

First tower crane TK10



1968

Breakthrough with the A 911 mobile material handler



1974

Silenced material handling machine



R 353 with the first industrial equipment

1961



Production plant in Kirchdorf

1970



First hydraulic cab elevation

1983

Liebherr has now been developing and manufacturing material handling machines for a very wide range of applications in the scrap, port and timber handling sectors and for the waste and recycling industry for over 50 years. In the development of its machines, Liebherr chooses quality, durability and reliability from the very outset, together with performance and economy. Years of experience in design and construction are

not only reflected in the end product but also in the components which are developed, designed and manufactured by Liebherr itself. This multiple sector expertise is used in product design from the early phase of the development process and thus allows high level technical innovations to be made.

2007

Opening of the assembly building for material handling machines



2013

Launch of the new LH series



2016

Launch of the new Port Material Handling Machines



Awarded the Bauma Design Prize for the LH 120

2010



Awarded the Bauma Innovation Prize for the ERC cylinder



Awarded the IF Award for the material handling machine LH 60

2014

Technical Data



Diesel Engine

Rating per ISO 9249	230 kW (313 HP) at 1,800 RPM
Model	Liebherr D946
Type	6 cylinder in-line
Bore/Stroke	130/150 mm
Displacement	11.95 l
Engine operation	4-stroke diesel Common-Rail turbo-charged and after-cooled reduced emissions
Air cleaner	dry-type air cleaner with pre-cleaner, primary and safety elements
Engine idling	sensor controlled
Electrical system	
Voltage	24 V
Batteries	2 x 180 Ah/12 V
Alternator	three-phase current 28 V/140 A
Stage V	
Harmful emissions values	according to regulation (EU) 2016/1628
Emission control	Liebherr-SCRFilter technology
Fuel tank	660 l
Urea tank	65 l
Stage IIIA (compliant)	
Harmful emissions values	in accordance with ECE-R.96 Power Band H
Fuel tank	660 l



Cooling System

Diesel engine	water-cooled cooling system, consisting of a cooling unit for water and charge air and a 2 nd cooler for hydraulic oil, each with an infinitely variable, thermostatically controlled fan drive system
----------------------	---



Hydraulic Controls

Power distribution	via control valves with integrated safety valves, simultaneous actuation of chassis and equipment. Swing drive in separate closed circuit
Servo circuit	
Equipment and swing	with electro-hydraulic pilot control and proportional joystick levers
Chassis	
Mobile	electro-proportional via foot pedal
Crawler	with electric proportionally functioning foot pedals or adjusted with plugable levers
Additional functions	via switch or electro-proportional foot pedals
Proportional control	proportionally acting transmitters on the joysticks for additional hydraulic functions



Hydraulic System

Hydraulic pump	
for equipment and travel drive	2 Liebherr axial piston variable displacement pumps (double construction)
Max. flow	2 x 362 l/min.
Max. pressure for swing drive	350 bar reversible axial piston variable displacement pump, closed-loop circuit
Max. flow	196 l/min.
Max. pressure	370 bar
Hydraulic pump regulation and control	2 circuit Liebherr-Synchron-Comfort-system (LSC) with electronic engine speed sensing regulation, pressure and flow compensation, automatic oil flow optimizer
Hydraulic tank	340 l
Hydraulic system	910 l
Hydraulic oil filter	2 main return filters with integrated partial micro filtration (5 µm)
MODE selection	adjustment of engine and hydraulic performance via a mode pre-selector to match application, e.g. for especially economical and environmentally friendly operation or for maximum material handling and heavy-duty jobs
S (Sensitive)	mode for precision work and lifting through very sensitive movements
E (Eco)	mode for especially economical and environmentally friendly operation
P (Power)	mode for high performance with low fuel consumption
P+ (Power-Plus)	mode for highest performance and for very heavy duty applications, suitable for continuous operation
Engine speed and performance setting	stepless alignment of engine output and hydraulic power via engine speed
Option	Tool Control: 20 preadjustable pump flows and pressures for add-on attachments



Swing Drive

Drive	Liebherr axial piston motor in a closed system, Liebherr planetary reduction gear
Swing ring	Liebherr, sealed race ball bearing swing ring, internal teeth
Swing speed	0 – 6.5 RPM stepless
Swing torque	141 kNm
Holding brake	wet multi-disc (spring applied, pressure released)
Option	slewing gear brake Comfort



Operator's Cab

Cab	safety cab structure with individual windscreens or featuring a slide-in subpart under the ceiling, work headlights integrated in the ceiling, a door with a sliding window (can be opened on both sides), large stowing and depositing possibilities, shock-absorbing suspension, sound damping insulating, tinted laminated safety glass, separate shades for the sunroof window and windscreen
High Rise/Gantry	deviating from standard: safety cab structure with fixed built-in front and roof window made from impact-resistant laminated safety glass
Operator's seat Comfort	air cushioned operator's seat with 3D-adjustable armrests, headrest, lap belt, seat heater, adjustable seat cushion inclination and length, lockable horizontal suspension, automatic weight adjustment, adjustable suspension stiffness, pneumatic lumbar vertebrae support and passive seat climatisation with active coal
Operator's seat Premium (Option)	in addition to operator's seat comfort: active electronic weight adjustment (automatic re-adjustment), pneumatic low frequency suspension and active seat climatisation with active coal and ventilator
Control system	joysticks with control consoles and swivel seat, folding left control console
Operation and displays	large high-resolution operating unit, self-explanatory, colour display with touchscreen, video-compatible, numerous setting, control and monitoring options, e.g. air conditioning control, fuel consumption, machine and attachment parameters
Air-conditioning	automatic air-conditioning, recirculated air function, fast de-icing and demisting at the press of a button, air vents can be operated via a menu; recirculated air and fresh air filters can be easily replaced and are accessible from the outside; heating-cooling unit, designed for extreme outside temperatures, sensors for solar radiation, inside and outside temperatures
Refrigerant	R134a
Global warming potential	1,430
Quantity at 25 °C *	1,400 – 2,000 g
CO ₂ equivalent *	2.002 – 2.86 t
Vibration emission**	
Hand/arm vibrations	< 2.5 m/s ²
Whole-body vibrations	< 0.5 m/s ²
Measuring inaccuracy	according with standard EN 12096:1997



Equipment

Type	high-strength steel plates at high stressed points for the toughest requirements. Complex and stable mountings of equipment and cylinders
Hydraulic cylinders	Liebherr cylinders with special sealing and guide system and, depending on cylinder type, shock absorption
Energy recovering cylinder	Liebherr gas cylinder with special sealing and control system
Bearings	sealed, low maintenance

* depending on configuration

** for risk assessment according to 2002/44/EC see ISO/TR 25398:2006



Undercarriage

Mobile	
Versions	Standard, High Rise
Drive	one axle drive per drive axle with Liebherr axial piston motor and functional brake valve on both sides (Standard); one driven axle with transmission with Liebherr axial piston motor and functional brake valve on both sides (High Rise)
Travel speed	
Joystick steering	0 – 3.5 km/h stepless (creeper speed) 0 – 10.0 km/h stepless 0 – 5.0 km/h stepless (creeper speed) (High Rise) 0 – 8.0 km/h stepless (High Rise)
Driving operation	automotive driving using accelerator pedal, cruise control function: storage of variable accelerator pedal positions
Axles	90 t drive axles; manual or automatic hydraulically controlled front axle oscillation lock
Service brake	two circuit travel brake system with accumulator; wet and backlash-free disc brake
Holding brake	wet multi-disc (spring applied, pressure released)
Stabilization	4 point outriggers
Crawler	
Versions	EW, SW, High Rise, Gantry
Drive	Liebherr compact planetary reduction gear with Liebherr axial piston motor per side of undercarriage
Travel speed	
EW	0 – 2.8 km/h stepless (creeper speed) 0 – 4.0 km/h stepless
SW	0 – 2.5 km/h stepless (creeper speed) 0 – 4.1 km/h stepless
High Rise	0 – 2.0 km/h stepless (creeper speed) 0 – 2.9 km/h stepless
Gantry	0 – 2.5 km/h stepless (creeper speed) 0 – 3.6 km/h stepless
Brake	functional brake valves on both sides
Holding brake	wet multi-disc (spring applied, pressure released)
Track pads	triple grouser, flat
Tracks	sealed and greased



Complete Machine

Lubrication	Liebherr central lubrication system for upper-carriage and equipment, automatically
Mobile (Option)	Liebherr central lubrication system for undercarriage, automatically
Steps system	safe and durable access system with anti-slip steps; main components hot-galvanised
Noise emission	
ISO 6396	L _{PA} (inside cab) = 70 dB(A) (Stage V)
2000/14/EC	L _{WA} (surround noise) = 105 dB(A) (Stage V)
ISO 6396	L _{PA} (inside cab) = 70 dB(A) (Stage IIIA compliant)
2000/14/EC	L _{WA} (surround noise) = 105 dB(A) (Stage IIIA compliant)

LH 80 M – Dimensions

Industry

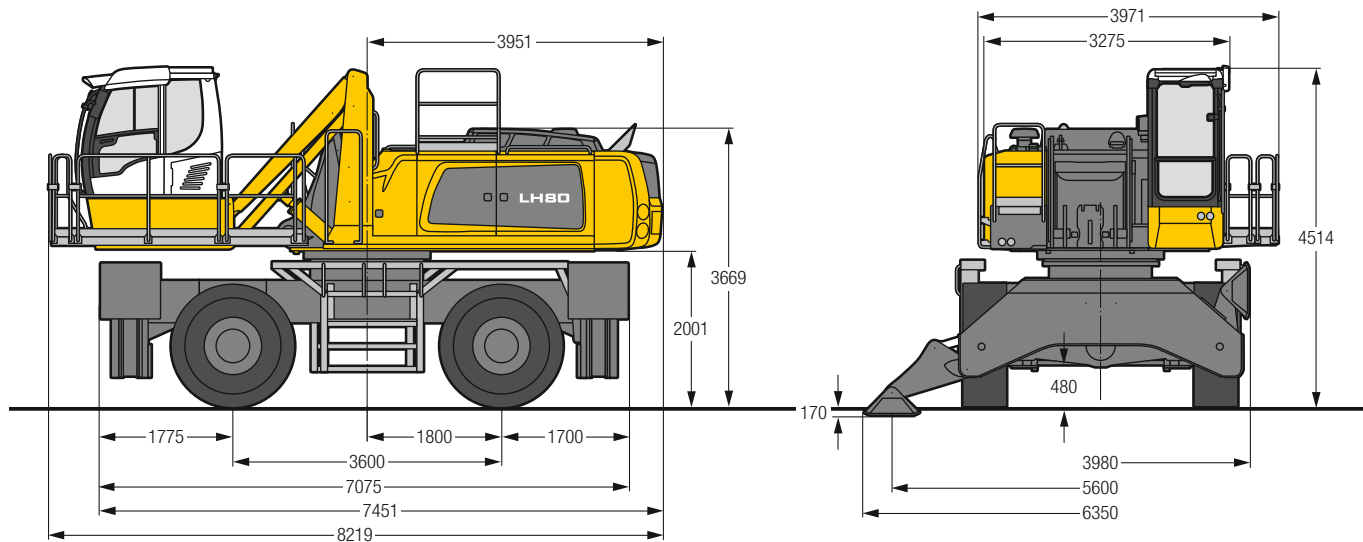

LH 80 M – Choice of Cab Elevation

Cab Elevation LFC (Rigid Elevation)

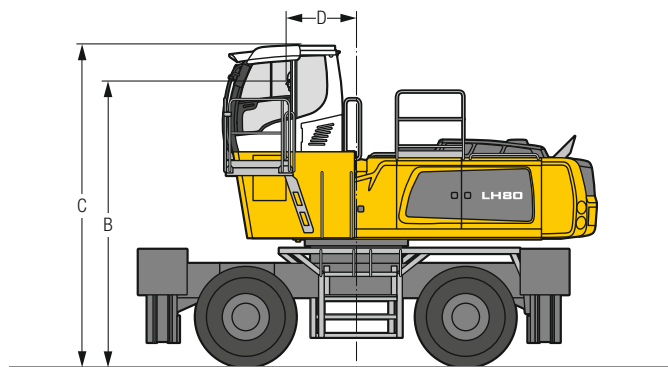

Increase type		LFC 120	LFC 200
Height	mm	1,200	2,000
B	mm	4,701	5,501
C	mm	5,214	6,014
D	mm	1,128	1,128

A rigid cab elevation has a fixed eye level height. For a lower transport height, the shell of the cab can be removed and replaced by a transport device. The dimension C is in this machine design for all rigid cab elevations 3,958 mm.

Cab Elevation LHC (Hydraulic Elevation)

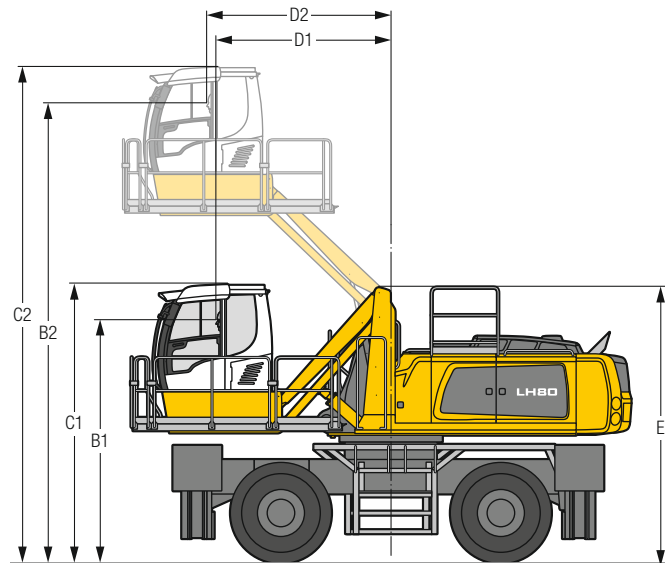

Increase type		LHC 255	LHC 340-35	LHC 360-50
B1	mm	3,501	3,852	4,001
B2	mm	6,048	7,267	7,571
C1	mm	4,014	4,366	4,514
C2	mm	6,561	7,780	8,085
D1	mm	1,683	2,796	2,854
D2	mm	1,809	2,797	3,004
E	mm	3,916	4,306	4,456

The hydraulically adjustable cab allows the driver, that he can choose his field of view freely and at any time within the stroke.

Tyres 23.5-25

LH 80 C EW/SW – Dimensions

Industry

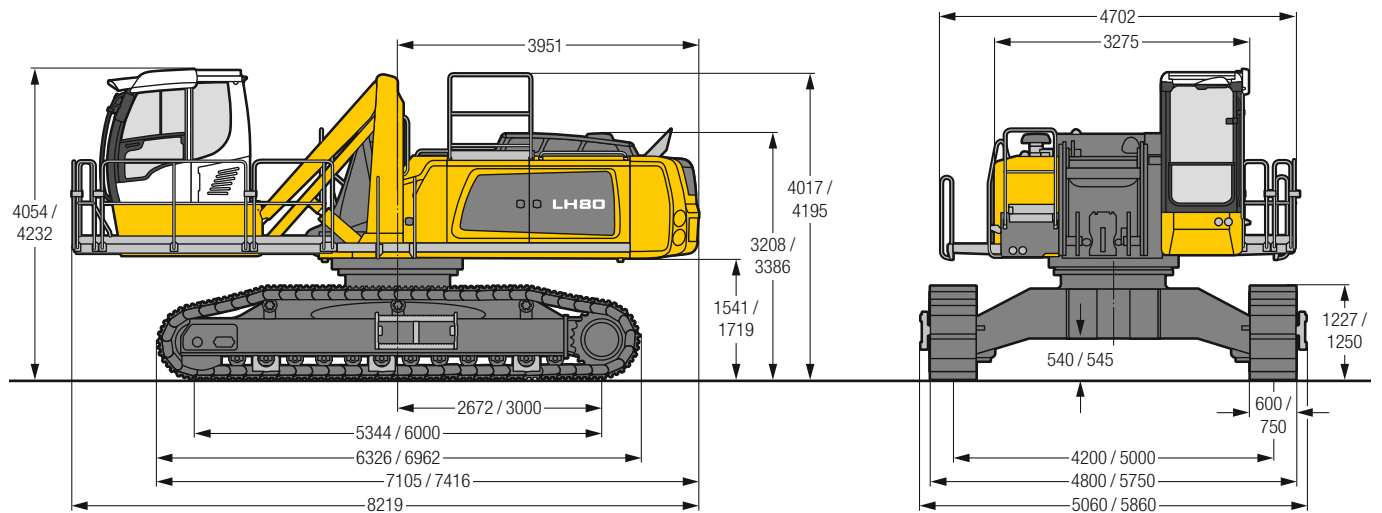

LH 80 C EW/SW – Choice of Cab Elevation

Cab Elevation LFC (Rigid Elevation)

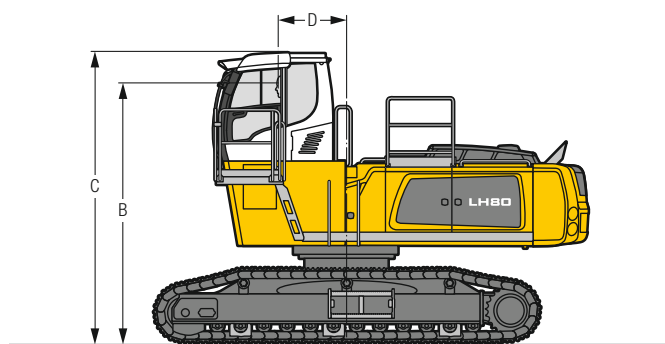

Increase type		LFC 120	LFC 200
Height	mm	1,200	2,000
B	mm	4,240 / 4,418	5,040 / 5,218
C	mm	4,754 / 4,932	5,554 / 5,732
D	mm	1,128	1,128

A rigid cab elevation has a fixed eye level height. For a lower transport height, the shell of the cab can be removed and replaced by a transport device. The dimension C is in this machine design for all rigid cab elevations 3,858 mm.

Cab Elevation LHC (Hydraulic Elevation)

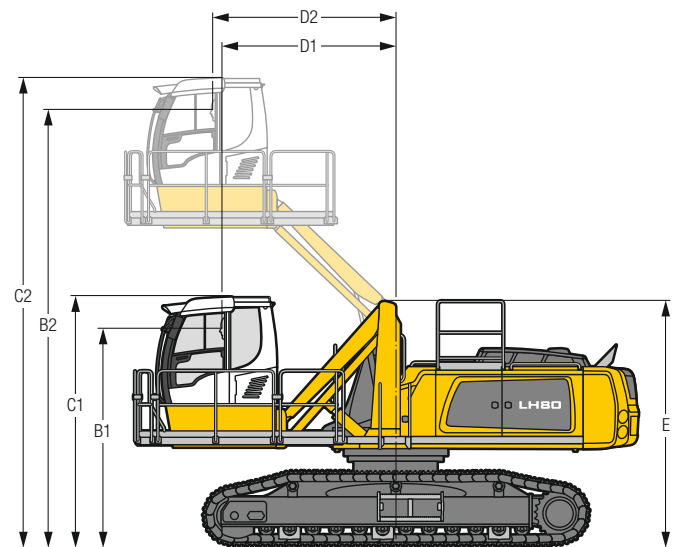

Increase type		LHC 255	LHC 340-35	LHC 360-50
B1	mm	3,040 / 3,218	3,392 / 3,570	3,540 / 3,718
B2	mm	5,587 / 5,765	6,807 / 6,985	7,111 / 7,289
C1	mm	3,554 / 3,732	3,905 / 4,083	4,054 / 4,232
C2	mm	6,101 / 6,279	7,320 / 7,498	7,625 / 7,803
D1	mm	1,683	2,796	2,854
D2	mm	1,809	2,797	3,004
E	mm	3,456 / 3,634	3,846 / 4,024	3,996 / 4,173

The hydraulically adjustable cab allows the driver, that he can choose his field of view freely and at any time within the stroke.

LH 80 M HR – Dimensions

Industry

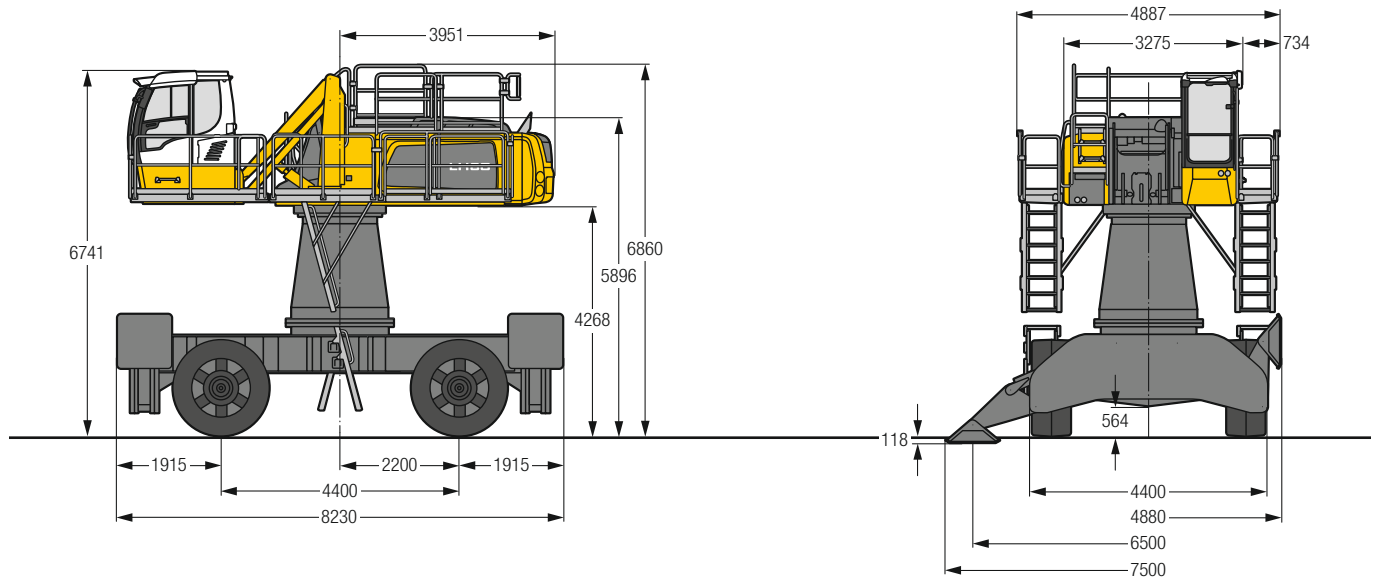

LH 80 M HR – Cab Elevation

Cab Elevation LHC (Hydraulic Elevation)

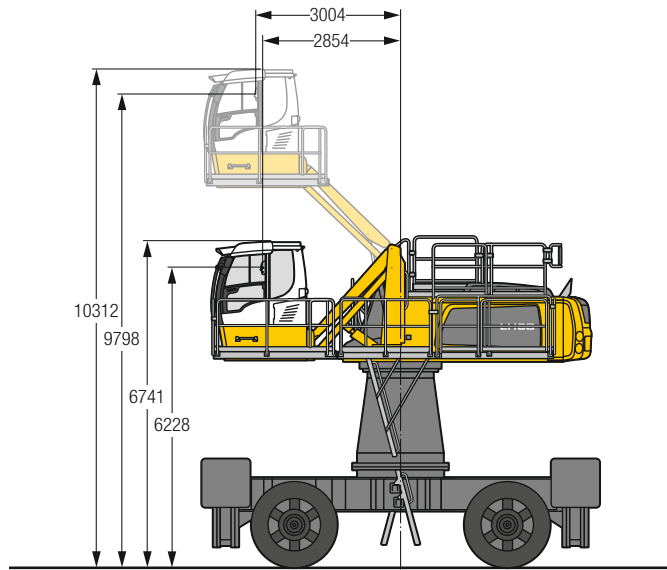

Increase type **LHC 360-50**
 The hydraulically adjustable cab allows the driver, that he can choose his field of view freely and at any time within the stroke.

Tyres 26.5-25

LH 80 C HR – Dimensions

Industry

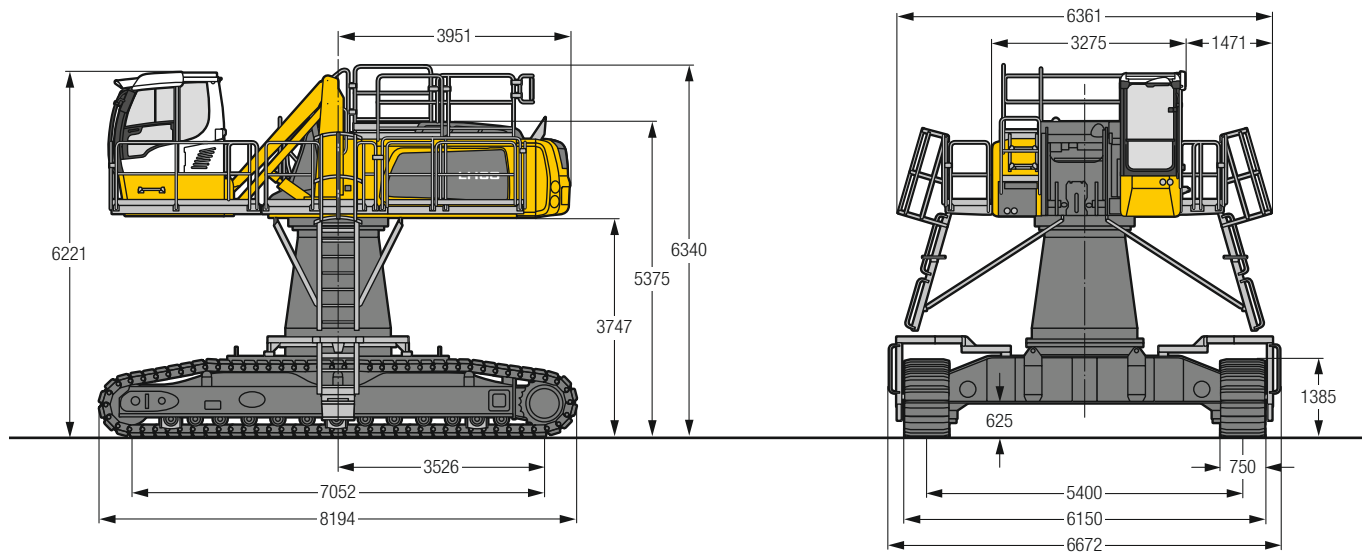

LH 80 C HR – Choice of Cab Elevation

Cab Elevation LHC (Hydraulic Elevation)

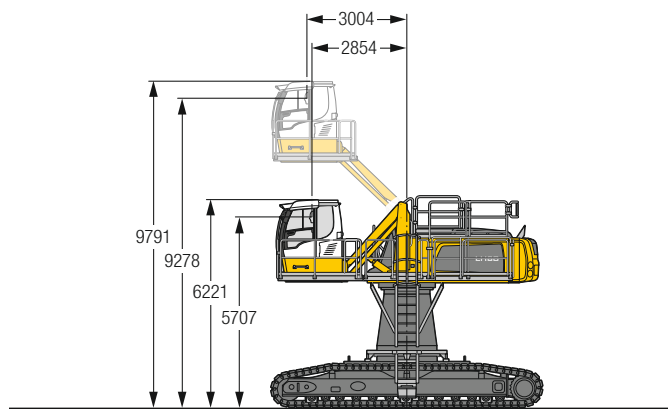

Increase type **LHC 360-50**
 The hydraulically adjustable cab allows the driver, that he can choose his field of view freely and at any time within the stroke.

Cab Elevation LHC-D (Hydraulic Elevation)

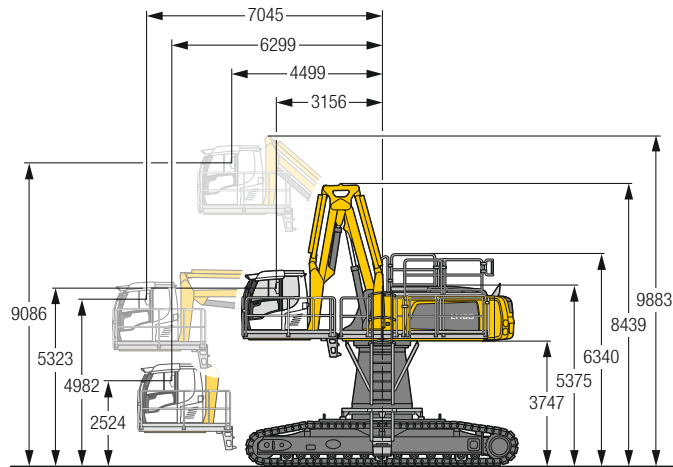

Increase type **LHC-D 730**
 The hydraulically adjustable cab allows the driver, that he can choose his field of view freely and at any time within the stroke.

LH 80 C Gantry – Dimensions

Industry

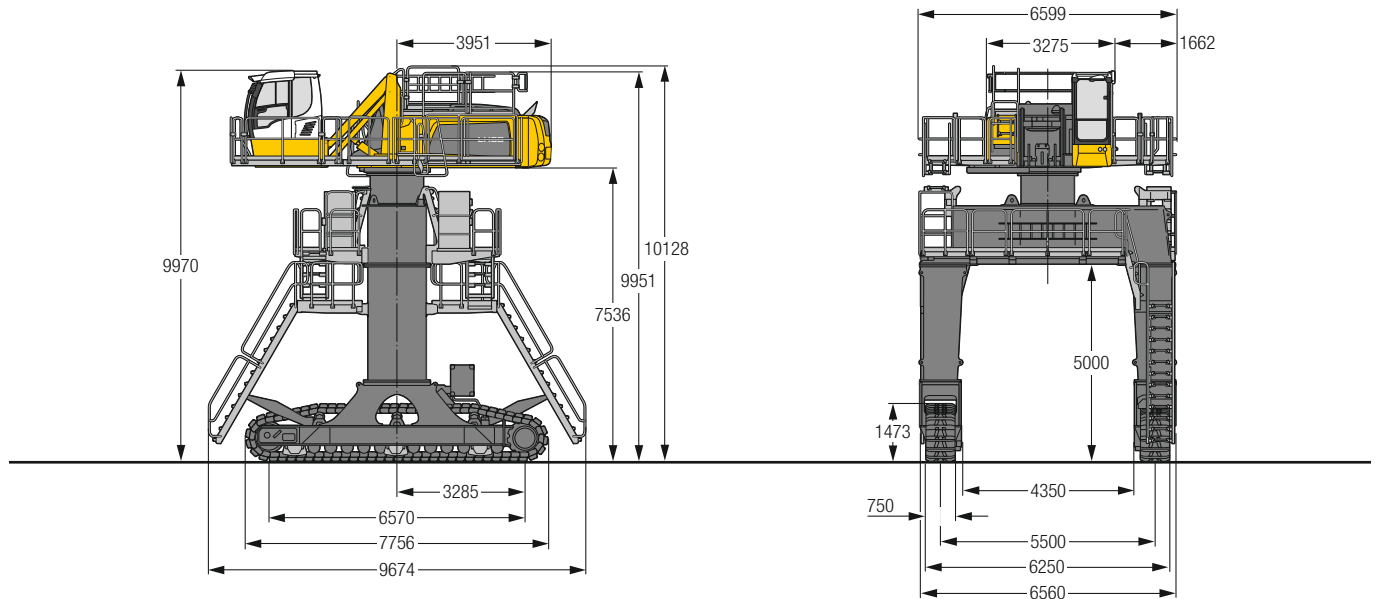

LH 80 C Gantry – Cab Elevation

Cab Elevation LHC (Hydraulic Elevation)

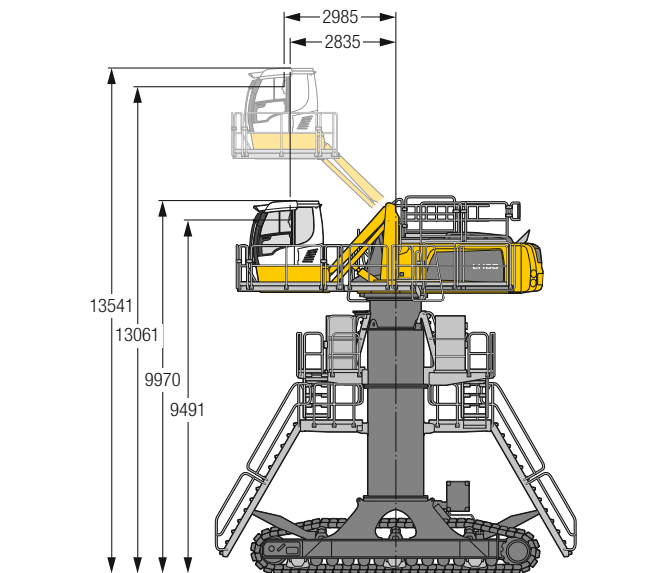

Increase type **LHC 360-50**
 The hydraulically adjustable cab allows the driver, that he can choose his field of view freely and at any time within the stroke.

Kinematic Variant 2A

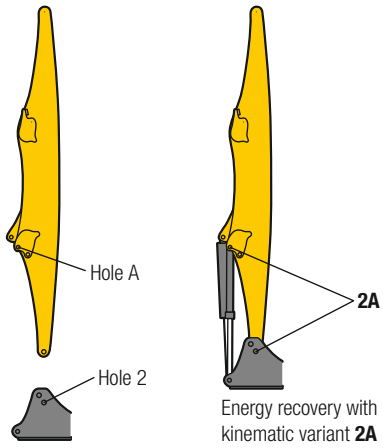

Kinematic Variant 2D/2C

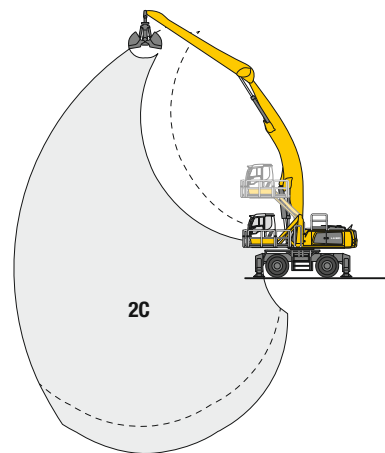
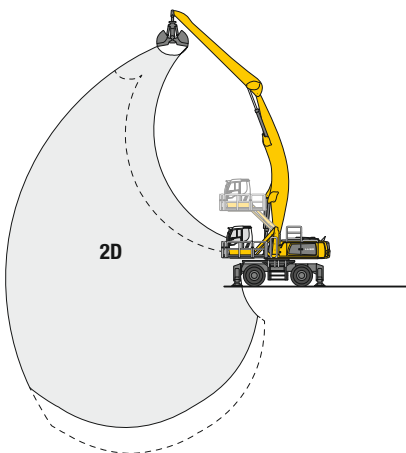
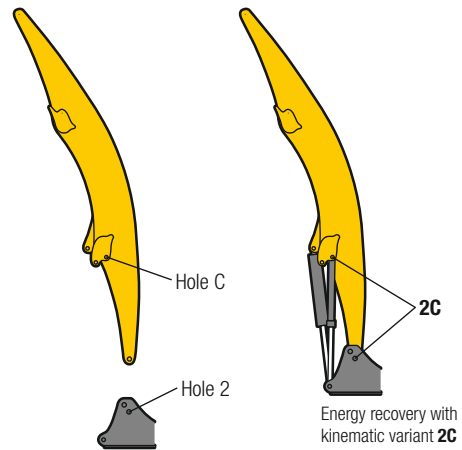
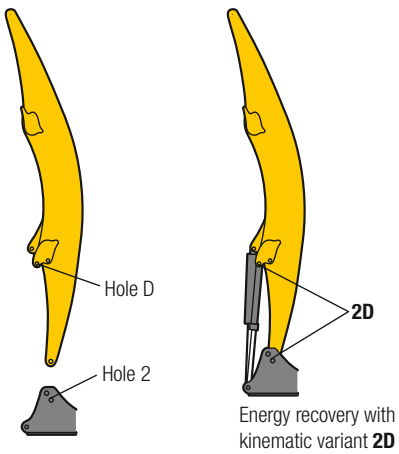

Altered range curve with additional reach depth, e.g. for unloading from ships

LH 80 M – Equipment GA18

Industry – Kinematic 2A

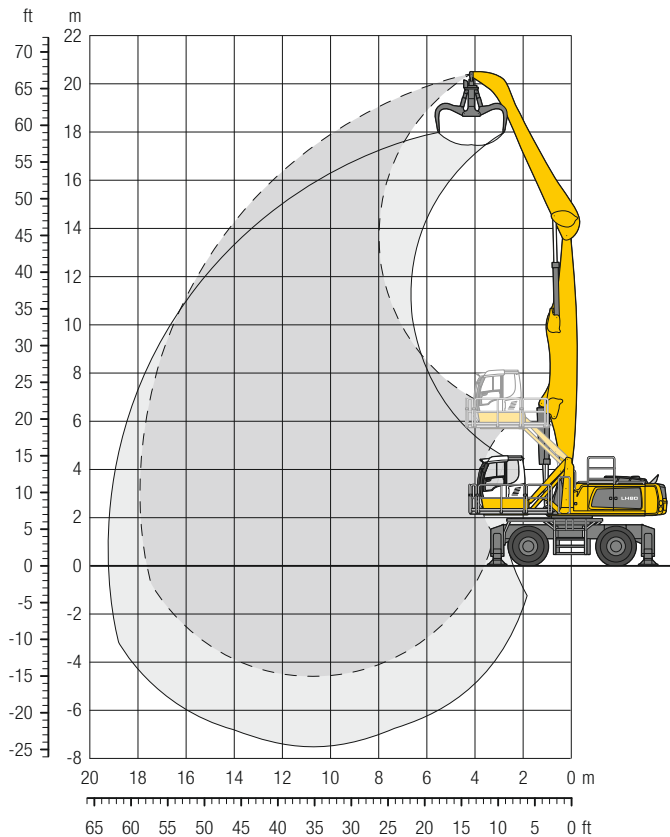

Operating Weight

The operating weight includes the basic machine with 4 point outriggers, hydr. cab elevation, 4 solid tyres, straight boom 10.50 m, angled stick 7.80 m and multi-tine grab GMM 80-5/ 1.70 m³ semi-closed tines.

Weight 75,800 kg

Dimensions

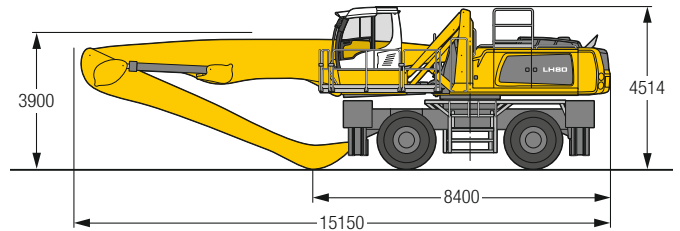

m	Undercarriage	6.0 m		7.5 m		9.0 m		10.5 m		12.0 m		13.5 m		15.0 m		16.5 m		18.0 m		19.5 m		21.0 m		m													
		4 pt. outriggers down	4 pt. outriggers down	4 pt. outriggers down	4 pt. outriggers down	4 pt. outriggers down	4 pt. outriggers down	4 pt. outriggers down	4 pt. outriggers down	4 pt. outriggers down	4 pt. outriggers down	4 pt. outriggers down	4 pt. outriggers down	4 pt. outriggers down	4 pt. outriggers down	4 pt. outriggers down	4 pt. outriggers down	4 pt. outriggers down	4 pt. outriggers down	4 pt. outriggers down	4 pt. outriggers down	4 pt. outriggers down	4 pt. outriggers down														
22.5	4 pt. outriggers down																																				
21.0	4 pt. outriggers down																																				
19.5	4 pt. outriggers down	15.1*	15.1*																																		
18.0	4 pt. outriggers down			14.8*	14.8*	12.6*	12.6*																		12.9*	12.9*	7.1										
16.5	4 pt. outriggers down			15.7*	15.7*	14.4*	14.4*	12.5*	12.5*																		10.6*	10.6*	9.9								
15.0	4 pt. outriggers down					15.4*	15.4*	13.8*	13.8*	12.2*	12.2*																		8.8*	8.8*	13.4						
13.5	4 pt. outriggers down					15.3*	15.3*	13.7*	13.7*	12.5*	12.5*	11.4*	11.4*																	8.4*	8.4*	14.6					
12.0	4 pt. outriggers down					15.4*	15.4*	13.8*	13.8*	12.5*	12.5*	11.5*	11.5*	10.1*	10.1*																8.1*	8.1*	15.6				
10.5	4 pt. outriggers down					17.3*	17.3*	15.7*	15.7*	13.9*	13.9*	12.6*	12.6*	11.5*	11.5*	10.6*	10.6*														7.9*	7.9*	16.3				
9.0	4 pt. outriggers down					18.6*	18.6*	16.1*	16.1*	14.2*	14.2*	12.8*	12.8*	11.6*	11.6*	10.7*	10.7*	9.7*	9.7*													7.9*	7.9*	16.9			
7.5	4 pt. outriggers down	19.5*	19.5*	19.5*	19.5*	16.7*	16.7*	14.6*	14.6*	13.1*	13.1*	11.8*	11.8*	10.8*	10.8*	9.6	9.6*															7.9*	7.9*	17.4			
6.0	4 pt. outriggers down	25.5*	25.5*	20.6*	20.6*	17.4*	17.4*	15.1*	15.1*	13.3*	13.3*	12.0*	12.0*	10.8*	10.8*	9.5	9.8*															7.9*	7.9*	17.7			
4.5	4 pt. outriggers down	27.5*	27.5*	21.8*	21.8*	18.1*	18.1*	15.5*	15.5*	13.6*	13.6*	12.1*	12.1*	10.9*	10.9*	9.3	9.7*																8.1*	8.1*	17.9		
3.0	4 pt. outriggers down	20.0*	20.0*	22.7*	22.7*	18.7*	18.7*	15.9*	15.9*	13.8*	13.8*	12.2*	12.2*	10.7	10.8*	9.2	9.6*																	8.1*	8.1*	17.9	
1.5	4 pt. outriggers down	10.5*	10.5*	23.2*	23.2*	19.0*	19.0*	16.1*	16.1*	13.9*	13.9*	12.2*	12.2*	10.4	10.7*	9.1	9.2*																	7.6*	7.6*	17.8	
0	4 pt. outriggers down	9.0*	9.0*	20.9*	20.9*	18.8*	18.8*	15.9*	15.9*	13.7*	13.7*	11.9*	11.9*	10.3*	10.3*	8.6*	8.6*																	7.0*	7.0*	17.6	
-1.5	4 pt. outriggers down	9.4*	9.4*	17.8*	17.8*	18.0*	18.0*	15.3*	15.3*	13.1*	13.1*	11.2*	11.2*	9.5*	9.5*	7.6*	7.6*																	6.8*	6.8*	16.9	
-3.0	4 pt. outriggers down			17.4*	17.4*	16.3*	16.3*	14.0*	14.0*	11.9*	11.9*	10.1*	10.1*	8.2*	8.2*																				7.6*	7.6*	15.4
-4.5	4 pt. outriggers down							11.9*	11.9*																										10.2*	10.2*	11.8

Height **Can be slewed through 360°** **In longitudinal position of undercarriage** **Max. reach** * Limited by hydr. capacity

The lift capacities on the stick end without attachment are stated in metric tons (t) and are valid on a firm, level supporting surface with blocked oscillating axle. These capacities can be slewed through 360° with the undercarriage in the transverse position. Capacities in the longitudinal position of the undercarriage (+/- 15°) are specified over the rigid axle with the stabilizers down. Indicated loads based on the ISO 10567 standard and do not exceed 75% of tipping or 87% of hydraulic capacity. The lift capacity values indicated are attained at the corresponding operating temperature. This operating temperature is ensured by continuous movement of the boom. Weights of fitted attachments (grabs, load hooks, etc.) and load accommodation attachment are to be deducted from the lift capacity values. The lift capacity of the unit is limited by its stability, the lifting capability of the hydraulic elements, or the maximum permissible lifting capacity of the load hook.

In accordance with the harmonised European Standard EN 474-5, hydraulic excavators used for lifting operations must be equipped with pipe fracture safety valves, an overload warning device, a load hook and a lift capacity chart.

LH 80 M – Equipment GA20

Industry – Kinematic 2A

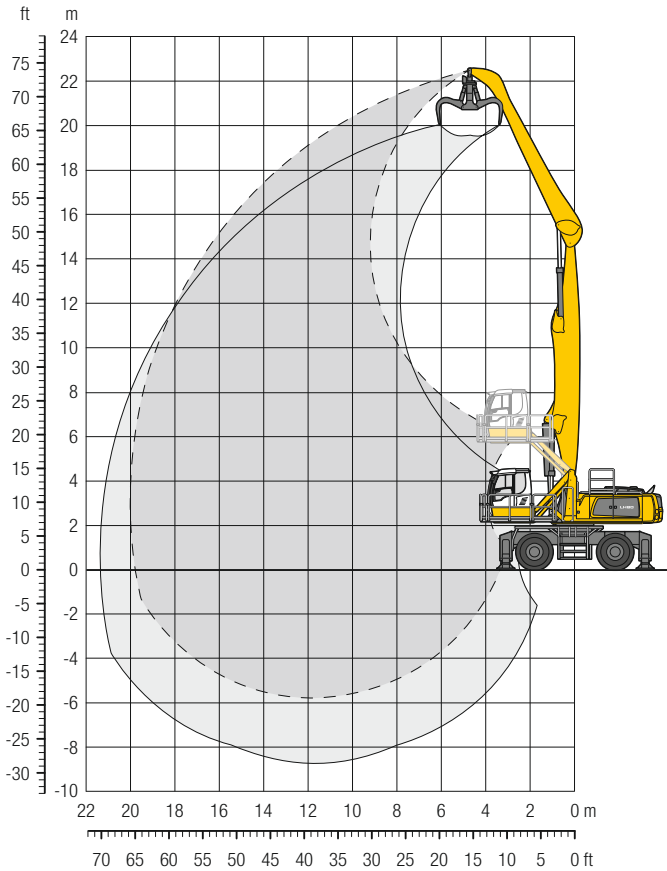

Operating Weight

The operating weight includes the basic machine with 4 point outriggers, hydr. cab elevation, 4 solid tyres, straight boom 11.50 m, angled stick 9.00 m and multi-tine grab GMM 80-5/ 1.70 m³ semi-closed tines.

Weight 76,800 kg

Dimensions

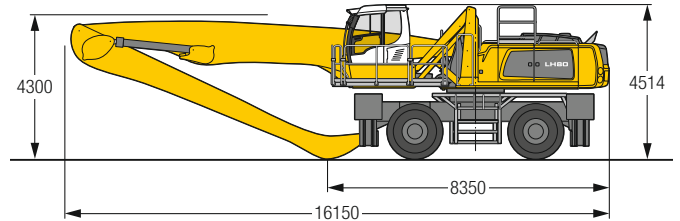

m	Reach (m)												m		
	6.0 m	7.5 m	9.0 m	10.5 m	12.0 m	13.5 m	15.0 m	16.5 m	18.0 m	19.5 m	21.0 m	m			
22.5	4 pt. outriggers down												14.5*	14.5*	4.7
21.0	4 pt. outriggers down												10.3*	10.3*	8.9
19.5	4 pt. outriggers down												8.8*	8.8*	11.5
18.0	4 pt. outriggers down												7.9*	7.9*	13.4
16.5	4 pt. outriggers down												7.4*	7.4*	14.9
15.0	4 pt. outriggers down												7.0*	7.0*	16.2
13.5	4 pt. outriggers down												6.8*	6.8*	17.2
12.0	4 pt. outriggers down												6.6*	6.6*	18.0
10.5	4 pt. outriggers down												6.6*	6.6*	18.7
9.0	4 pt. outriggers down												6.5*	6.5*	19.2
7.5	4 pt. outriggers down												6.5*	6.5*	19.6
6.0	4 pt. outriggers down												6.6*	6.6*	19.8
4.5	4 pt. outriggers down												6.4	6.7*	20.0
3.0	4 pt. outriggers down												6.4	6.4*	20.0
1.5	4 pt. outriggers down												6.0*	6.0*	20.0
0	4 pt. outriggers down												5.5*	5.5*	19.8
-1.5	4 pt. outriggers down												5.0*	5.0*	19.4
-3.0	4 pt. outriggers down												5.4*	5.4*	18.2
-4.5	4 pt. outriggers down												6.2*	6.2*	16.4

Height **Can be slewed through 360°** **In longitudinal position of undercarriage** **Max. reach** * Limited by hydr. capacity

The lift capacities on the stick end without attachment are stated in metric tons (t) and are valid on a firm, level supporting surface with blocked oscillating axle. These capacities can be slewed through 360° with the undercarriage in the transverse position. Capacities in the longitudinal position of the undercarriage (+/- 15°) are specified over the rigid axle with the stabilizers down. Indicated loads based on the ISO 10567 standard and do not exceed 75% of tipping or 87% of hydraulic capacity. The lift capacity values indicated are attained at the corresponding operating temperature. This operating temperature is ensured by continuous movement of the boom. Weights of fitted attachments (grabs, load hooks, etc.) and load accommodation attachment are to be deducted from the lift capacity values. The lift capacity of the unit is limited by its stability, the lifting capability of the hydraulic elements, or the maximum permissible lifting capacity of the load hook.

In accordance with the harmonised European Standard EN 474-5, hydraulic excavators used for lifting operations must be equipped with pipe fracture safety valves, an overload warning device, a load hook and a lift capacity chart.

LH 80 M – Equipment GA21

Industry – Kinematic 2A

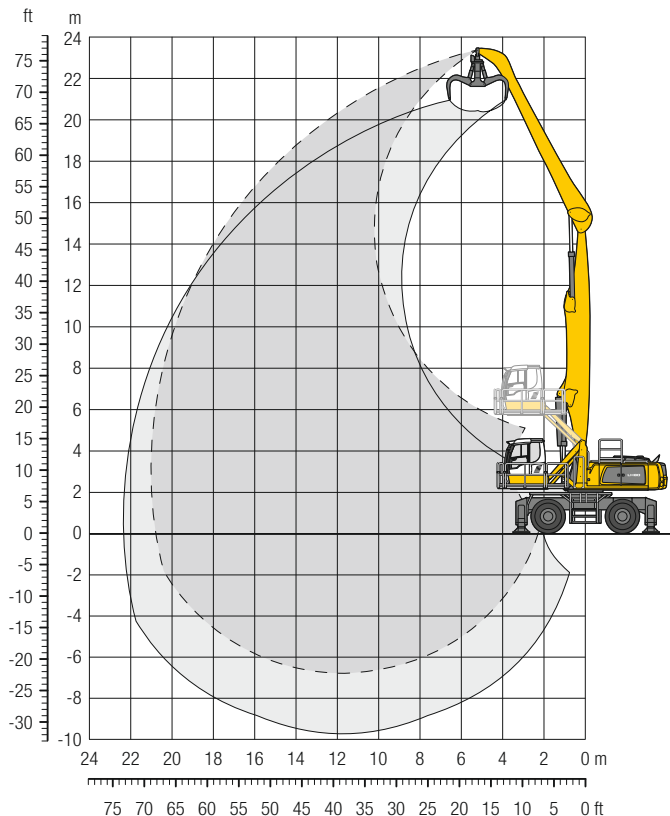

Operating Weight

The operating weight includes the basic machine with 4 point outriggers, hydr. cab elevation, 4 solid tyres, straight boom 11.50 m, angled stick 10.00 m and multi-tine grab GMM 80-5/ 1.40 m³ semi-closed tines.

Weight 77,200 kg

Dimensions

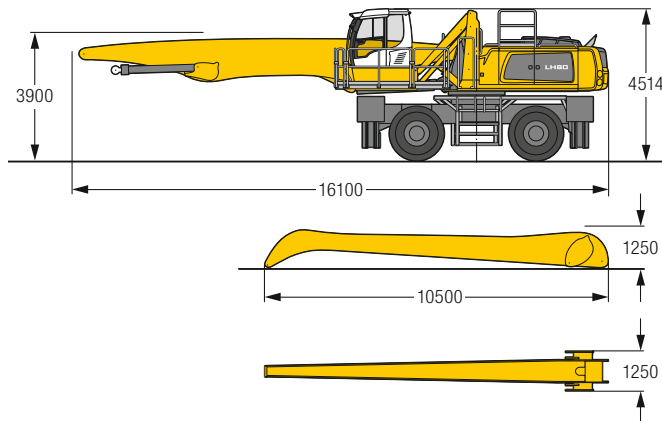

m	Undercarriage	6.0 m		7.5 m		9.0 m		10.5 m		12.0 m		13.5 m		15.0 m		16.5 m		18.0 m		19.5 m		21.0 m		m			
		4 pt. outriggers down	4 pt. outriggers down	4 pt. outriggers down	4 pt. outriggers down	4 pt. outriggers down	4 pt. outriggers down	4 pt. outriggers down	4 pt. outriggers down	4 pt. outriggers down	4 pt. outriggers down	4 pt. outriggers down	4 pt. outriggers down	4 pt. outriggers down	4 pt. outriggers down	4 pt. outriggers down	4 pt. outriggers down	4 pt. outriggers down	4 pt. outriggers down	4 pt. outriggers down	4 pt. outriggers down	4 pt. outriggers down	4 pt. outriggers down				
24.0	4 pt. outriggers down																										
22.5	4 pt. outriggers down			10.9*	10.9*																		10.2*	10.2*	7.9		
21.0	4 pt. outriggers down					10.9*	10.9*	9.1*	9.1*															8.3*	8.3*	11.0	
19.5	4 pt. outriggers down							11.8*	11.8*	10.7*	10.7*	9.2*	9.2*											7.4*	7.4*	13.1	
18.0	4 pt. outriggers down									11.4*	11.4*	10.4*	10.4*	8.9*	8.9*										6.8*	6.8*	14.8
16.5	4 pt. outriggers down									11.8*	11.8*	11.1*	11.1*	10.1*	10.1*	8.5*	8.5*								6.4*	6.4*	16.2
15.0	4 pt. outriggers down									12.1*	12.1*	11.0*	11.0*	10.0*	10.0*	9.2*	9.2*	7.8*	7.8*						6.1*	6.1*	17.3
13.5	4 pt. outriggers down									12.2*	12.2*	11.0*	11.0*	10.0*	10.0*	9.2*	9.2*	8.5*	8.5*	6.6*	6.6*				5.9*	5.9*	18.3
12.0	4 pt. outriggers down									12.3*	12.3*	11.1*	11.1*	10.1*	10.1*	9.2*	9.2*	8.5*	8.5*	7.9*	7.9*				5.8*	5.8*	19.1
10.5	4 pt. outriggers down									12.5*	12.5*	11.2*	11.2*	10.1*	10.1*	9.3*	9.3*	8.5*	8.5*	7.9*	7.9*	6.2*	6.2*		5.7*	5.7*	19.7
9.0	4 pt. outriggers down					13.5*	13.5*	12.8*	12.8*	11.4*	11.4*	10.3*	10.3*	9.4*	9.4*	8.6*	8.6*	7.9*	7.9*	7.1*	7.3*				5.7*	5.7*	20.2
7.5	4 pt. outriggers down			13.4*	13.4*	15.0*	15.0*	13.1*	13.1*	11.6*	11.6*	10.4*	10.4*	9.5*	9.5*	8.6*	8.6*	7.9*	7.9*	7.0*	7.2*				5.7*	5.7*	20.6
6.0	4 pt. outriggers down	13.8*	13.8*	16.7*	16.7*	15.7*	15.7*	13.5*	13.5*	11.9*	11.9*	10.6*	10.6*	9.6*	9.6*	8.7*	8.7*	7.9*	7.9*	6.9*	7.2*				5.7*	5.7*	20.8
4.5	4 pt. outriggers down	24.6*	24.6*	19.6*	19.6*	16.3*	16.3*	13.9*	13.9*	12.2*	12.2*	10.8*	10.8*	9.7*	9.7*	8.8*	8.8*	7.8*	7.9*	6.8*	7.1*				5.8*	5.8*	21.0
3.0	4 pt. outriggers down	26.1*	26.1*	20.5*	20.5*	16.8*	16.8*	14.3*	14.3*	12.4*	12.4*	11.0*	11.0*	9.8*	9.8*	8.8*	8.8*	7.6*	7.9*	6.6*	7.0*	5.8	5.9*	5.8	5.9*	21.0	
1.5	4 pt. outriggers down	12.0*	12.0*	21.1*	21.1*	17.2*	17.2*	14.6*	14.6*	12.6*	12.6*	11.0*	11.0*	9.8*	9.8*	8.6*	8.7*	7.4*	7.8*	6.5*	6.8*				5.5*	5.5*	20.9
0	4 pt. outriggers down	7.9*	7.9*	19.7*	19.7*	17.4*	17.4*	14.6*	14.6*	12.6*	12.6*	11.0*	11.0*	9.7*	9.7*	8.4*	8.6*	7.3*	7.5*	6.4*	6.4*				5.1*	5.1*	20.8
-1.5	4 pt. outriggers down	7.2*	7.2*	14.3*	14.3*	17.1*	17.1*	14.4*	14.4*	12.4*	12.4*	10.8*	10.8*	9.4*	9.4*	8.2*	8.3*	7.1*	7.1*	5.8*	5.8*				4.6*	4.6*	20.5
-3.0	4 pt. outriggers down	7.5*	7.5*	12.8*	12.8*	16.3*	16.3*	13.9*	13.9*	11.9*	11.9*	10.3*	10.3*	8.9*	8.9*	7.7*	7.7*	6.4*	6.4*	4.8*	4.8*				4.7*	4.7*	19.6
-4.5	4 pt. outriggers down	8.2*	8.2*	12.7*	12.7*	14.9*	14.9*	12.8*	12.8*	11.0*	11.0*	9.5*	9.5*	8.1*	8.1*	6.8*	6.8*	5.3*	5.3*						5.2*	5.2*	18.1
-6.0	4 pt. outriggers down					12.7*	12.7*	11.1*	11.1*	9.6*	9.6*	8.2*	8.2*	6.8*	6.8*										6.3*	6.3*	15.6

Height **Can be slewed through 360°** **In longitudinal position of undercarriage** **Max. reach** * Limited by hydr. capacity

The lift capacities on the stick end without attachment are stated in metric tons (t) and are valid on a firm, level supporting surface with blocked oscillating axle. These capacities can be slewed through 360° with the undercarriage in the transverse position. Capacities in the longitudinal position of the undercarriage (+/- 15°) are specified over the rigid axle with the stabilizers down. Indicated loads based on the ISO 10567 standard and do not exceed 75% of tipping or 87% of hydraulic capacity. The lift capacity values indicated are attained at the corresponding operating temperature. This operating temperature is ensured by continuous movement of the boom. Weights of fitted attachments (grabs, load hooks, etc.) and load accommodation attachment are to be deducted from the lift capacity values. The lift capacity of the unit is limited by its stability, the lifting capability of the hydraulic elements, or the maximum permissible lifting capacity of the load hook.

In accordance with the harmonised European Standard EN 474-5, hydraulic excavators used for lifting operations must be equipped with pipe fracture safety valves, an overload warning device, a load hook and a lift capacity chart.

LH 80 M – Equipment GA22

Industry – Kinematic 2A

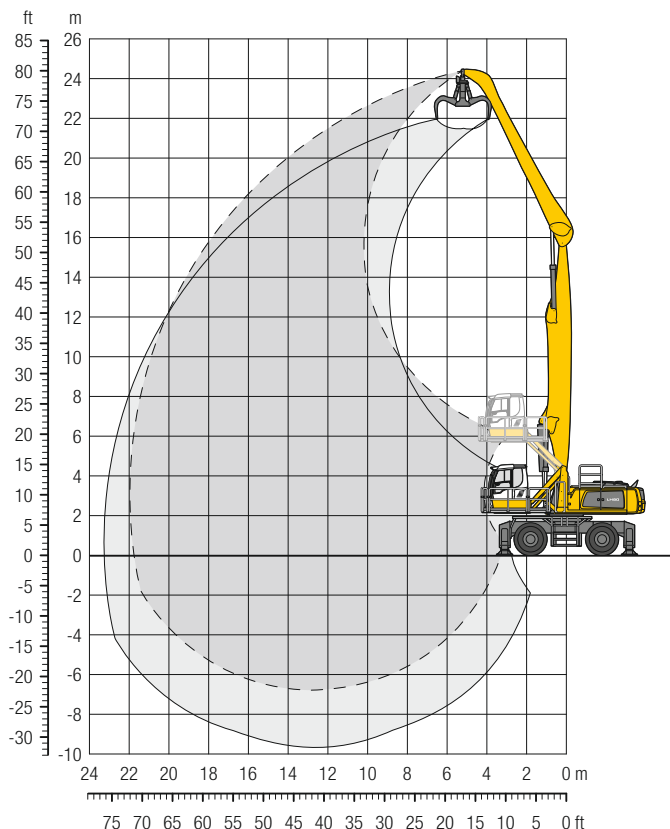

Operating Weight

The operating weight includes the basic machine with 4 point outriggers, hydr. cab elevation, 4 solid tyres, straight boom 12.50 m, angled stick 10.00 m and multi-tine grab GMM 80-5/ 1.40 m³ semi-closed tines.

Weight 78,000 kg

Dimensions

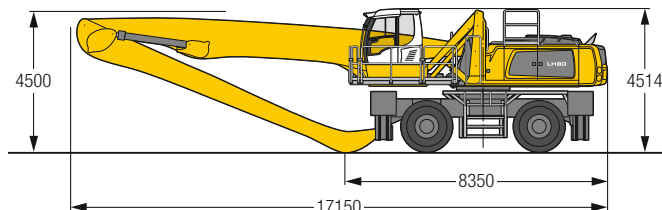

m	Undercarriage	6.0 m		7.5 m		9.0 m		10.5 m		12.0 m		13.5 m		15.0 m		16.5 m		18.0 m		19.5 m		21.0 m		m		
		4 pt. outriggers down	4 pt. outriggers down	4 pt. outriggers down	4 pt. outriggers down	4 pt. outriggers down	4 pt. outriggers down	4 pt. outriggers down	4 pt. outriggers down	4 pt. outriggers down	4 pt. outriggers down	4 pt. outriggers down	4 pt. outriggers down	4 pt. outriggers down	4 pt. outriggers down	4 pt. outriggers down	4 pt. outriggers down	4 pt. outriggers down	4 pt. outriggers down	4 pt. outriggers down	4 pt. outriggers down	4 pt. outriggers down	4 pt. outriggers down	4 pt. outriggers down	4 pt. outriggers down	4 pt. outriggers down
24.0	4 pt. outriggers down	12.3*	12.3*																					11.5*	11.5*	6.6
22.5	4 pt. outriggers down					10.5*	10.5*																	8.8*	8.8*	10.3
21.0	4 pt. outriggers down					11.6*	11.6*	10.4*	10.4*	8.8*	8.8*													7.7*	7.7*	12.7
19.5	4 pt. outriggers down							11.3*	11.3*	10.3*	10.3*	8.8*	8.8*											7.0*	7.0*	14.6
18.0	4 pt. outriggers down							11.7*	11.7*	10.9*	10.9*	9.8*	9.8*											6.5*	6.5*	16.2
16.5	4 pt. outriggers down							12.1*	12.1*	10.8*	10.8*	9.8*	9.8*	8.9*	8.9*	8.0*	8.0*							6.2*	6.2*	17.4
15.0	4 pt. outriggers down							12.2*	12.2*	10.8*	10.8*	9.7*	9.7*	8.8*	8.8*	8.1*	8.1*	7.1*	7.1*					6.0*	6.0*	18.5
13.5	4 pt. outriggers down							12.2*	12.2*	10.8*	10.8*	9.7*	9.7*	8.8*	8.8*	8.1*	8.1*	7.4*	7.4*					5.8*	5.8*	19.4
12.0	4 pt. outriggers down							12.3*	12.3*	10.9*	10.9*	9.8*	9.8*	8.9*	8.9*	8.1*	8.1*	7.4*	7.4*	6.8*	6.8*			5.7*	5.7*	20.1
10.5	4 pt. outriggers down					13.2*	13.2*	12.5*	12.5*	11.0*	11.0*	9.9*	9.9*	8.9*	8.9*	8.1*	8.1*	7.4*	7.4*	6.8*	6.8*			5.7*	5.7*	20.7
9.0	4 pt. outriggers down					14.3*	14.3*	12.7*	12.7*	11.2*	11.2*	10.0*	10.0*	9.0*	9.0*	8.1*	8.1*	7.4*	7.4*	6.8*	6.8*	5.8	6.1*	5.7*	5.7*	21.2
7.5	4 pt. outriggers down	12.4*	12.4*	15.0*	15.0*	15.1*	15.1*	13.0*	13.0*	11.3*	11.3*	10.1*	10.1*	9.0*	9.0*	8.2*	8.2*	7.4*	7.4*	6.8*	6.8*	5.8	6.1*	5.4	5.7*	21.6
6.0	4 pt. outriggers down	19.1*	19.1*	18.7*	18.7*	15.5*	15.5*	13.2*	13.2*	11.5*	11.5*	10.2*	10.2*	9.1*	9.1*	8.2*	8.2*	7.5*	7.5*	6.6	6.7*	5.7	6.0*	5.3	5.5*	21.8
4.5	4 pt. outriggers down	24.7*	24.7*	19.4*	19.4*	15.9*	15.9*	13.5*	13.5*	11.7*	11.7*	10.3*	10.3*	9.2*	9.2*	8.2*	8.2*	7.4*	7.4*	6.5	6.7*	5.6	5.9*	5.1	5.3*	21.9
3.0	4 pt. outriggers down	10.5*	10.5*	19.9*	19.9*	16.2*	16.2*	13.7*	13.7*	11.8*	11.8*	10.4*	10.4*	9.2*	9.2*	8.2*	8.2*	7.3	7.4*	6.3	6.6*	5.5	5.7*	5.0*	5.0*	22.0
1.5	4 pt. outriggers down	5.4*	5.4*	15.8*	15.8*	16.4*	16.4*	13.8*	13.8*	11.9*	11.9*	10.4*	10.4*	9.2*	9.2*	8.1	8.1*	7.0	7.2*	6.1	6.4*	5.4	5.5*	4.7*	4.7*	21.9
0	4 pt. outriggers down	4.6*	4.6*	10.4*	10.4*	16.2*	16.2*	13.7*	13.7*	11.8*	11.8*	10.3*	10.3*	9.0*	9.0*	7.8	8.0*	6.8	7.0*	6.0	6.1*	5.0*	5.0*	4.3*	4.3*	21.7
-1.5	4 pt. outriggers down	4.9*	4.9*	9.1*	9.1*	15.7*	15.7*	13.3*	13.3*	11.5*	11.5*	10.0*	10.0*	8.7*	8.7*	7.6	7.7*	6.7*	6.7*	5.6*	5.6*	4.4*	4.4*	3.8*	3.8*	21.5
-3.0	4 pt. outriggers down	5.5*	5.5*	9.0*	9.0*	14.6*	14.6*	12.6*	12.6*	10.9*	10.9*	9.5*	9.5*	8.2*	8.2*	7.1*	7.1*	6.1*	6.1*	4.9*	4.9*			3.9*	3.9*	20.6
-4.5	4 pt. outriggers down			9.4*	9.4*	13.0*	13.0*	11.4*	11.4*	9.9*	9.9*	8.6*	8.6*	7.5*	7.5*	6.4*	6.4*	5.2*	5.2*					4.3*	4.3*	19.1
-6.0	4 pt. outriggers down					10.8*	10.8*	9.7*	9.7*	8.5*	8.5*	7.4*	7.4*	6.3*	6.3*	5.2*	5.2*							5.1*	5.1*	16.6

Height Can be slewed through 360° In longitudinal position of undercarriage Max. reach * Limited by hydr. capacity

The lift capacities on the stick end without attachment are stated in metric tons (t) and are valid on a firm, level supporting surface with blocked oscillating axle. These capacities can be slewed through 360° with the undercarriage in the transverse position. Capacities in the longitudinal position of the undercarriage (+/- 15°) are specified over the rigid axle with the stabilizers down. Indicated loads based on the ISO 10567 standard and do not exceed 75% of tipping or 87% of hydraulic capacity. The lift capacity values indicated are attained at the corresponding operating temperature. This operating temperature is ensured by continuous movement of the boom. Weights of fitted attachments (grabs, load hooks, etc.) and load accommodation attachment are to be deducted from the lift capacity values. The lift capacity of the unit is limited by its stability, the lifting capability of the hydraulic elements, or the maximum permissible lifting capacity of the load hook.

In accordance with the harmonised European Standard EN 474-5, hydraulic excavators used for lifting operations must be equipped with pipe fracture safety valves, an overload warning device, a load hook and a lift capacity chart.

LH 80 M – Equipment AG21

Industry – Kinematic 2D

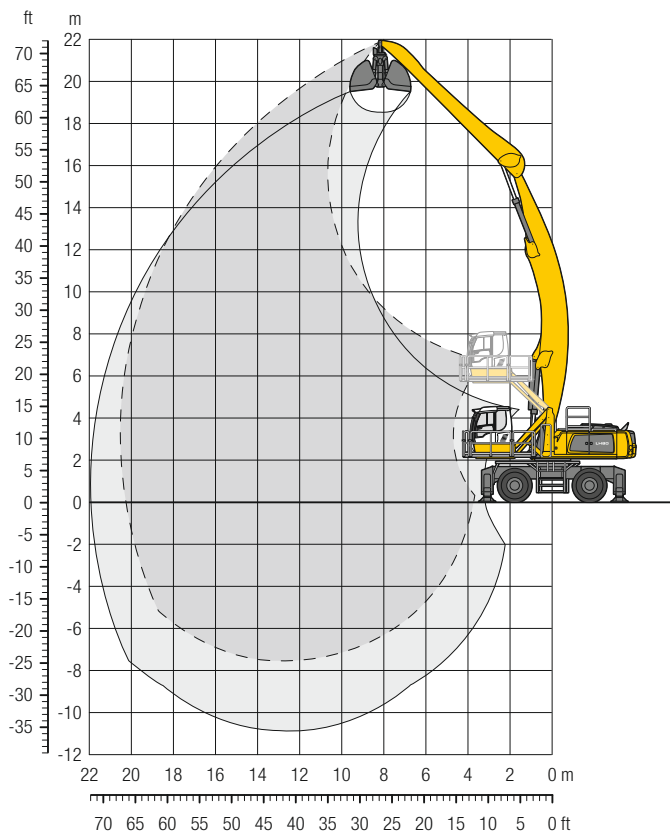

Operating Weight

The operating weight includes the basic machine with 4 point outriggers, hydr. cab elevation, 4 solid tyres, angled boom 12.50 m, straight stick 9.00 m and grab for loose material GMZ 80/ 3.00 m³.

Weight 78,100 kg

Dimensions

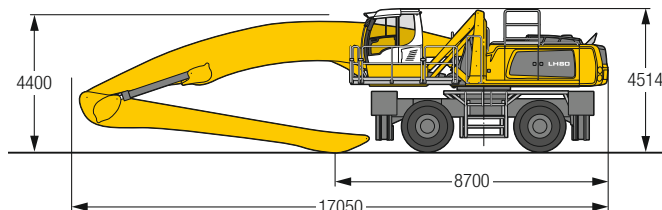

m	6.0 m		7.5 m		9.0 m		10.5 m		12.0 m		13.5 m		15.0 m		16.5 m		18.0 m		19.5 m		21.0 m		m	
	4 pt. outriggers down	4 pt. outriggers down	4 pt. outriggers down	4 pt. outriggers down	4 pt. outriggers down	4 pt. outriggers down	4 pt. outriggers down	4 pt. outriggers down	4 pt. outriggers down	4 pt. outriggers down	4 pt. outriggers down	4 pt. outriggers down	4 pt. outriggers down	4 pt. outriggers down	4 pt. outriggers down	4 pt. outriggers down	4 pt. outriggers down	4 pt. outriggers down	4 pt. outriggers down	4 pt. outriggers down	4 pt. outriggers down	4 pt. outriggers down		
22.5																								
21.0					10.7*	10.7*																8.8*	8.8*	10.4
19.5							10.8*	10.8*	9.0*	9.0*												7.9*	7.9*	12.6
18.0							10.6*	10.6*	9.5*	9.5*	8.7*	8.7*										7.4*	7.4*	14.4
16.5									9.4*	9.4*	8.6*	8.6*	8.0*	8.0*								7.0*	7.0*	15.8
15.0									9.4*	9.4*	8.6*	8.6*	7.9*	7.9*	7.4*	7.4*						6.8*	6.8*	17.0
13.5							10.5*	10.5*	9.4*	9.4*	8.6*	8.6*	7.9*	7.9*	7.3*	7.3*						6.6*	6.6*	17.9
12.0							10.7*	10.7*	9.6*	9.6*	8.7*	8.7*	7.9*	7.9*	7.4*	7.4*	6.9*	6.9*				6.6*	6.6*	18.7
10.5							10.9*	10.9*	9.7*	9.7*	8.8*	8.8*	8.0*	8.0*	7.4*	7.4*	6.9*	6.9*				6.5*	6.5*	19.4
9.0					12.9*	12.9*	11.2*	11.2*	9.9*	9.9*	8.9*	8.9*	8.1*	8.1*	7.5*	7.5*	6.9*	6.9*	6.5*	6.5*		6.4*	6.4*	19.9
7.5			19.9*	19.9*	16.0*	16.0*	13.4*	13.4*	11.6*	11.6*	10.2*	10.2*	9.1*	9.1*	8.3*	8.3*	7.6*	7.6*	7.0*	7.0*	6.5*	6.5*	20.3	
6.0			21.3*	21.3*	16.9*	16.9*	14.0*	14.0*	12.0*	12.0*	10.5*	10.5*	9.4*	9.4*	8.4*	8.4*	7.7*	7.7*	7.1*	7.1*	6.6*	6.6*	20.5	
4.5			20.5*	20.5*	17.8*	17.8*	14.6*	14.6*	12.4*	12.4*	10.8*	10.8*	9.6*	9.6*	8.6*	8.6*	7.8*	7.8*	7.2*	7.2*	6.6*	6.6*	20.7	
3.0			6.9*	6.9*	18.7*	18.7*	15.2*	15.2*	12.8*	12.8*	11.1*	11.1*	9.8*	9.8*	8.8*	8.8*	7.9*	7.9*	7.2*	7.2*	6.4*	6.6*	20.7	
1.5			5.0*	5.0*	12.2*	12.2*	15.7*	15.7*	13.2*	13.2*	11.4*	11.4*	10.0*	10.0*	8.9*	8.9*	8.0*	8.0*	7.2*	7.3*	6.3*	6.6*	20.6	
0			4.9*	4.9*	9.7*	9.7*	15.9*	15.9*	13.4*	13.4*	11.5*	11.5*	10.1*	10.1*	9.0*	9.0*	8.0*	8.0*	7.0*	7.2*	6.1*	6.5*	20.4	
-1.5			5.5*	5.5*	9.2*	9.2*	15.9*	15.9*	13.4*	13.4*	11.6*	11.6*	10.1*	10.1*	9.0*	9.0*	7.8*	8.0*	6.8*	7.1*	6	6.2*	20.2	
-3.0			6.3*	6.3*	9.4*	9.4*	15.4*	15.4*	13.2*	13.2*	11.4*	11.4*	10.0*	10.0*	8.8*	8.8*	7.6*	7.8*	6.7*	6.8*	5.8*	5.8*	19.7	
-4.5			7.2*	7.2*	10.0*	10.0*	14.8*	14.8*	12.7*	12.7*	11.0*	11.0*	9.6*	9.6*	8.5*	8.5*	7.4*	7.4*	6.3*	6.3*			19.2	
-6.0					13.5*	13.5*	11.8*	11.8*	10.3*	10.3*	9.0*	9.0*	7.8*	7.8*	6.7*	6.7*						5.8*	5.8*	17.7
-7.5							9.2*	9.2*	8.0*	8.0*												7.9*	7.9*	13.6

Height **Can be slewed through 360°** **In longitudinal position of undercarriage** **Max. reach** * Limited by hydr. capacity

The lift capacities on the stick end without attachment are stated in metric tons (t) and are valid on a firm, level supporting surface with blocked oscillating axle. These capacities can be slewed through 360° with the undercarriage in the transverse position. Capacities in the longitudinal position of the undercarriage (+/- 15°) are specified over the rigid axle with the stabilizers down. Indicated loads based on the ISO 10567 standard and do not exceed 75% of tipping or 87% of hydraulic capacity. The lift capacity values indicated are attained at the corresponding operating temperature. This operating temperature is ensured by continuous movement of the boom. Weights of fitted attachments (grabs, load hooks, etc.) and load accommodation attachment are to be deducted from the lift capacity values. The lift capacity of the unit is limited by its stability, the lifting capability of the hydraulic elements, or the maximum permissible lifting capacity of the load hook.

In accordance with the harmonised European Standard EN 474-5, hydraulic excavators used for lifting operations must be equipped with pipe fracture safety valves, an overload warning device, a load hook and a lift capacity chart.

LH 80 M – Equipment AG22

Industry – Kinematic 2D

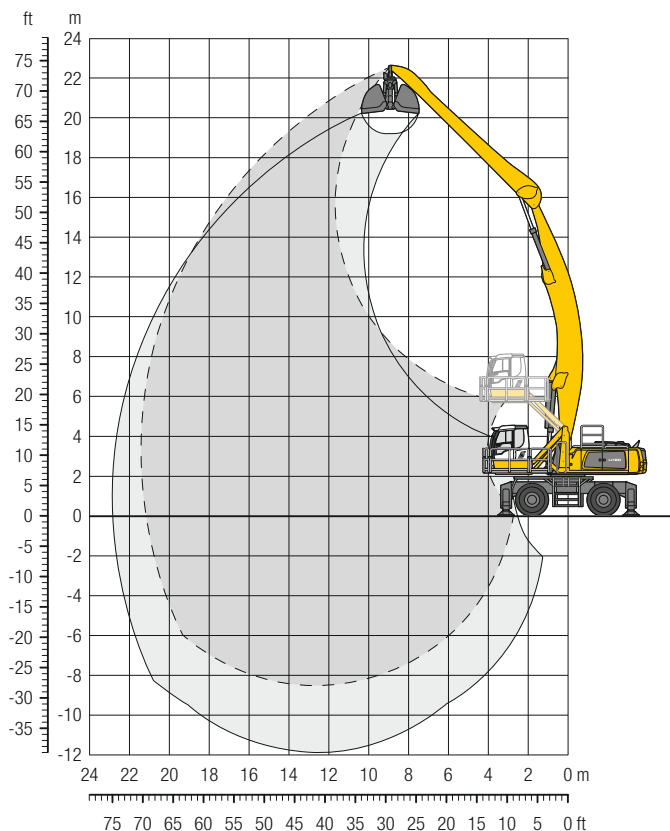

Operating Weight

The operating weight includes the basic machine with 4 point outriggers, hydr. cab elevation, 4 solid tyres, angled boom 12.50 m, straight stick 10.00 m and grab for loose material GMZ 80/ 3.00 m³.

Weight 78,500 kg

Dimensions

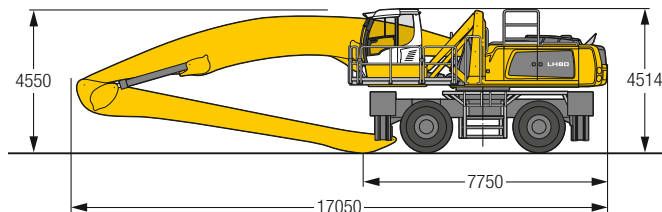

m	6.0 m		7.5 m		9.0 m		10.5 m		12.0 m		13.5 m		15.0 m		16.5 m		18.0 m		19.5 m		21.0 m		m				
	4 pt. outriggers down	4 pt. outriggers down	4 pt. outriggers down	4 pt. outriggers down	4 pt. outriggers down	4 pt. outriggers down	4 pt. outriggers down	4 pt. outriggers down	4 pt. outriggers down	4 pt. outriggers down	4 pt. outriggers down	4 pt. outriggers down	4 pt. outriggers down	4 pt. outriggers down	4 pt. outriggers down	4 pt. outriggers down	4 pt. outriggers down	4 pt. outriggers down	4 pt. outriggers down	4 pt. outriggers down	4 pt. outriggers down	4 pt. outriggers down					
22.5					8.4*	8.4*																	8.4*	8.4*	9.0		
21.0							8.7*	8.7*																7.2*	7.2*	11.8	
19.5									8.8*	8.8*	7.1*	7.1*											6.6*	6.6*	13.8		
18.0									9.1*	9.1*	8.3*	8.3*	6.9*	6.9*									6.2*	6.2*	15.4		
16.5									9.0*	9.0*	8.2*	8.2*	7.5*	7.5*	6.4*	6.4*							6.0*	6.0*	16.7		
15.0									9.0*	9.0*	8.1*	8.1*	7.5*	7.5*	7.0*	7.0*							5.8*	5.8*	17.9		
13.5									9.0*	9.0*	8.2*	8.2*	7.5*	7.5*	6.9*	6.9*	6.5*	6.5*					5.7*	5.7*	18.8		
12.0									9.1*	9.1*	8.2*	8.2*	7.5*	7.5*	7.0*	7.0*	6.5*	6.5*	5.7*	5.7*			5.6*	5.6*	19.5		
10.5							10.4*	10.4*	9.3*	9.3*	8.3*	8.3*	7.6*	7.6*	7.0*	7.0*	6.5*	6.5*	6.1*	6.1*			5.6*	5.6*	20.1		
9.0							10.7*	10.7*	9.5*	9.5*	8.5*	8.5*	7.7*	7.7*	7.1*	7.1*	6.6*	6.6*	6.1*	6.1*			5.7*	5.7*	20.6		
7.5					12.7*	12.7*	11.0*	11.0*	9.7*	9.7*	8.7*	8.7*	7.9*	7.9*	7.2*	7.2*	6.6*	6.6*	6.2*	6.2*			5.7*	5.7*	21.0		
6.0			19.9*	19.9*	15.9*	15.9*	13.3*	13.3*	11.4*	11.4*	10.0*	10.0*	8.9*	8.9*	8.0*	8.0*	7.3*	7.3*	6.7*	6.7*	6.2*	6.2*	5.8*	5.8*	5.6	5.7*	21.2
4.5			21.4*	21.4*	16.8*	16.8*	13.9*	13.9*	11.8*	11.8*	10.3*	10.3*	9.1*	9.1*	8.2*	8.2*	7.4*	7.4*	6.8*	6.8*	6.3*	6.3*	5.7	5.8*	5.4	5.7*	21.4
3.0			15.2*	15.2*	17.7*	17.7*	14.4*	14.4*	12.2*	12.2*	10.6*	10.6*	9.3*	9.3*	8.3*	8.3*	7.5*	7.5*	6.9*	6.9*	6.3*	6.3*	5.5	5.8*	5.3	5.6*	21.4
1.5			7.8*	7.8*	18.4*	18.4*	14.9*	14.9*	12.6*	12.6*	10.8*	10.8*	9.5*	9.5*	8.5*	8.5*	7.6*	7.6*	6.9*	6.9*	6.2	6.3*	5.4	5.7*	5.2	5.6*	21.4
0			6.4*	6.4*	12.6*	12.6*	15.3*	15.3*	12.8*	12.8*	11.0*	11.0*	9.7*	9.7*	8.6*	8.6*	7.7*	7.7*	6.9	7.0*	6.0	6.3*	5.3	5.6*	5.2	5.5*	21.2
-1.5			6.3*	6.3*	10.7*	10.7*	15.5*	15.5*	13.0*	13.0*	11.2*	11.2*	9.8*	9.8*	8.6*	8.6*	7.7	7.7*	6.7	6.9*	5.9	6.2*			5.3	5.4*	20.9
-3.0			6.6*	6.6*	10.1*	10.1*	15.3*	15.3*	13.0*	13.0*	11.1*	11.1*	9.7*	9.7*	8.6*	8.6*	7.5	7.6*	6.5	6.8*	5.8	5.9*			5.3*	5.3*	20.5
-4.5			7.2*	7.2*	10.2*	10.2*	14.9*	14.9*	12.7*	12.7*	10.9*	10.9*	9.5*	9.5*	8.4*	8.4*	7.3	7.4*	6.5	6.5*	5.5*	5.5*			5.1*	5.1*	20.0
-6.0			7.8*	7.8*	10.6*	10.6*	14.0*	14.0*	12.0*	12.0*	10.4*	10.4*	9.1*	9.1*	7.9*	7.9*	6.9*	6.9*	5.9*	5.9*					4.9*	4.9*	19.3
-7.5					12.6*	12.6*	11.0*	11.0*	9.6*	9.6*	8.3*	8.3*	7.2*	7.2*	6.1*	6.1*							5.7*	5.7*	17.1		

Height Can be slewed through 360° In longitudinal position of undercarriage Max. reach * Limited by hydr. capacity

The lift capacities on the stick end without attachment are stated in metric tons (t) and are valid on a firm, level supporting surface with blocked oscillating axle. These capacities can be slewed through 360° with the undercarriage in the transverse position. Capacities in the longitudinal position of the undercarriage (+/- 15°) are specified over the rigid axle with the stabilizers down. Indicated loads based on the ISO 10567 standard and do not exceed 75% of tipping or 87% of hydraulic capacity. The lift capacity values indicated are attained at the corresponding operating temperature. This operating temperature is ensured by continuous movement of the boom. Weights of fitted attachments (grabs, load hooks, etc.) and load accommodation attachment are to be deducted from the lift capacity values. The lift capacity of the unit is limited by its stability, the lifting capability of the hydraulic elements, or the maximum permissible lifting capacity of the load hook.

In accordance with the harmonised European Standard EN 474-5, hydraulic excavators used for lifting operations must be equipped with pipe fracture safety valves, an overload warning device, a load hook and a lift capacity chart.

LH 80 C EW – Equipment GA18

Industry – Kinematic 2A

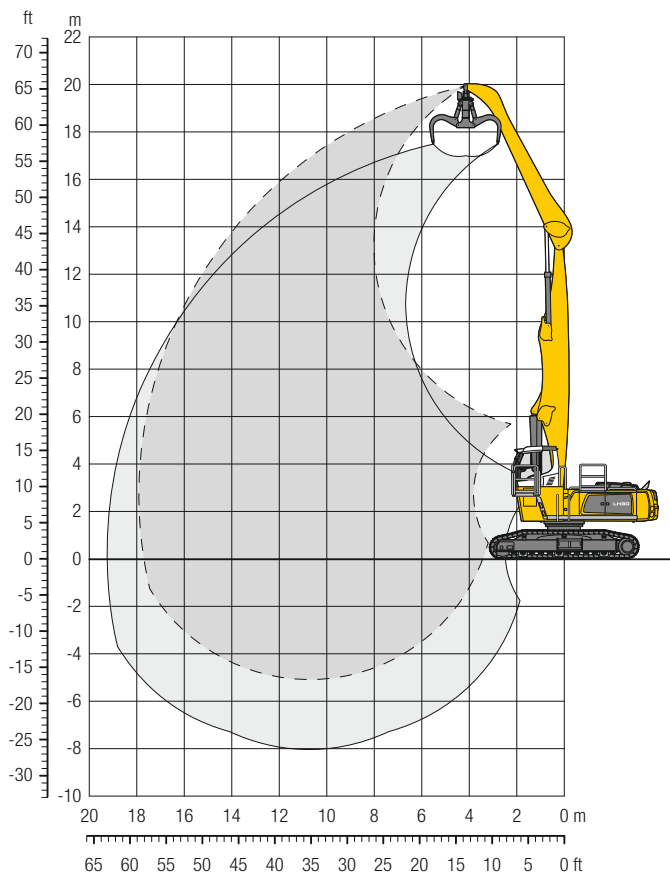

Operating Weight and Ground Pressure

The operating weight includes the basic machine with rigid cab elevation, straight boom 10.50 m, angled stick 7.80 m and multi-tine grab GMM 80-5/1.70 m³ semi-closed tines.

Weight	68,000 kg
Pad width	600 mm
Ground pressure	on request

Dimensions

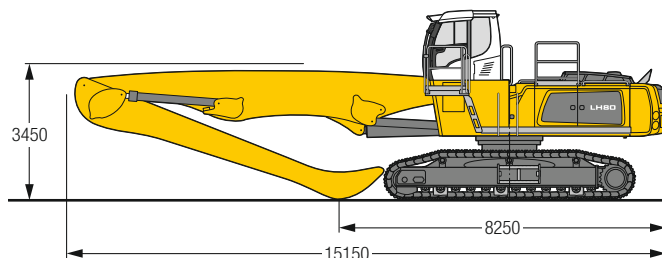

m	Undercarriage	6.0 m		7.5 m		9.0 m		10.5 m		12.0 m		13.5 m		15.0 m		16.5 m		18.0 m		19.5 m		21.0 m		m		
		EW	EW	EW	EW	EW	EW	EW	EW	EW	EW	EW	EW	EW	EW	EW	EW	EW	EW	EW	EW	EW	EW			
21.0	EW																						14.5*	14.5*	5.7	
19.5	EW																							11.2*	11.2*	9.1
18.0	EW			14.2*	14.2*	11.4*	11.4*																	9.8*	9.8*	11.3
16.5	EW			15.5*	15.5*	14.0*	14.0*	11.7*	11.7*															9.0*	9.0*	12.9
15.0	EW					13.9*	13.9*	12.4*	12.4*	11.3*	11.3*													8.4	8.5*	14.2
13.5	EW					13.8*	13.8*	12.3*	12.3*	11.2*	11.2*	9.4	10.3*											7.3	8.2*	15.3
12.0	EW					13.8*	13.8*	12.3*	12.3*	11.1*	11.1*	9.5	10.2*	7.6	9.1*									6.6	8.0*	16.1
10.5	EW					13.9*	13.9*	12.4*	12.4*	11.2*	11.2*	9.5	10.2*	7.7	9.4*	6.2	8.1							6.0	7.8	16.7
9.0	EW			16.5*	16.5*	14.3*	14.3*	12.6*	12.6*	11.3*	11.3*	9.3	10.3*	7.6	9.4*	6.2	8.1							5.6	7.3	17.2
7.5	EW	18.2*	18.2*	17.2*	17.2*	14.7*	14.7*	12.9*	12.9*	11.2	11.5*	9.1	10.4*	7.4	9.5*	6.2	8.0							5.3	7.0	17.6
6.0	EW	22.3*	22.3*	18.1*	18.1*	15.3*	15.3*	13.3*	13.3*	10.7	11.7*	8.8	10.5*	7.3	9.4	6.1	7.9							5.1	6.8	17.8
4.5	EW	24.0*	24.0*	19.1*	19.1*	15.9*	15.9*	12.7	13.7*	10.2	12.0*	8.4	10.7*	7.0	9.1	5.9	7.8							5.0	6.6	17.9
3.0	EW	25.5*	25.5*	19.9	20.0*	15.1	16.4*	12.0	14.0*	9.7	12.2*	8.1	10.5	6.8	8.9	5.8	7.6							5.0	6.6	17.9
1.5	EW	12.0*	12.0*	18.4	20.5*	14.2	16.8*	11.3	14.2*	9.3	12.2	7.8	10.2	6.6	8.7	5.6	7.5							5.0	6.6	17.9
0	EW	9.2*	9.2*	17.3	20.5*	13.4	16.8*	10.8	14.2*	8.9	11.8	7.5	9.9	6.4	8.5	5.5	7.4							5.0	6.3*	17.7
-1.5	EW	9.2*	9.2*	16.7	18.4*	12.9	16.3*	10.4	13.8*	8.6	11.5	7.3	9.7	6.3	8.3	5.5	7.0*							5.1	5.8*	17.3
-3.0	EW	10.0*	10.0*	16.3	17.4*	12.6	15.1*	10.1	12.9*	8.4	11.0*	7.2	9.3*	6.2	7.7*									5.7	6.3*	16.1
-4.5	EW					12.5	13.0*	10.0	11.2*	8.4	9.5*	7.1	7.9*											7.0	7.6*	13.7
-6.0	EW																									

Height Can be slewed through 360° In longitudinal position of undercarriage Max. reach * Limited by hydr. capacity

The lift capacities on the stick end without attachment are stated in metric tons (t) and can be slewed through 360° on a firm, level supporting surface. Capacities are valid for 600 mm wide triple grouser pads (resp. flat pads). Indicated loads based on the ISO 10567 standard and do not exceed 75% of tipping or 87% of hydraulic capacity. The lift capacity values indicated are attained at the corresponding operating temperature. This operating temperature is ensured by continuous movement of the boom. Weights of fitted attachments (grabs, load hooks, etc.) and load accommodation attachment are to be deducted from the lift capacity values. The lift capacity of the unit is limited by its stability, the lifting capability of the hydraulic elements, or the maximum permissible lifting capacity of the load hook. In accordance with the harmonised European Standard EN 474-5, hydraulic excavators used for lifting operations must be equipped with pipe fracture safety valves, an overload warning device, a load hook and a lift capacity chart.

LH 80 C EW – Equipment GA20

Industry – Kinematic 2A

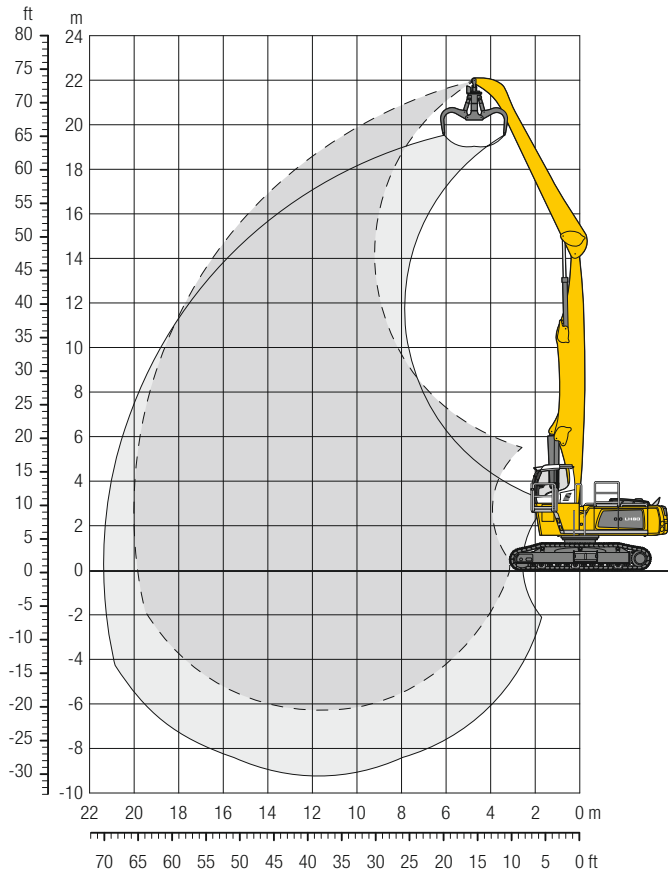

Operating Weight and Ground Pressure

The operating weight includes the basic machine with rigid cab elevation, straight boom 11.50 m, angled stick 9.00 m and multi-tine grab GMM 80-5/1.70 m³ semi-closed tines.

Weight	69,000 kg
Pad width	600 mm
Ground pressure	on request

Dimensions

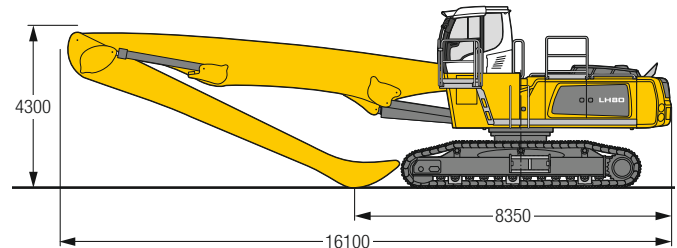

m	Undercarriage	6.0 m		7.5 m		9.0 m		10.5 m		12.0 m		13.5 m		15.0 m		16.5 m		18.0 m		19.5 m		21.0 m		m			
		EW	EW	EW	EW	EW	EW	EW	EW	EW	EW	EW	EW	EW	EW	EW	EW	EW	EW	EW	EW	EW	EW	EW	EW	EW	
21.0	EW			11.7*	11.7*																			11.2*	11.2*	7.8	
19.5	EW			13.3*	13.3*	11.8*	11.8*	9.6*	9.6*															9.2*	9.2*	10.7	
18.0	EW					12.9*	12.9*	11.6*	11.6*	9.7*	9.7*													8.2*	8.2*	12.8	
16.5	EW					13.1*	13.1*	11.5*	11.5*	10.3*	10.3*	9.4*	9.4*											7.6*	7.6*	14.4	
15.0	EW							11.4*	11.4*	10.2*	10.2*	9.3*	9.3*	7.8	8.5*									6.9	7.2*	15.8	
13.5	EW							11.4*	11.4*	10.2*	10.2*	9.2*	9.2*	7.9	8.5*	6.3	7.8*							6.0	6.9*	16.8	
12.0	EW							13.0*	13.0*	11.4*	11.4*	10.2*	10.2*	9.2*	9.2*	7.9	8.4*	6.4	7.8*					5.3	6.7*	17.7	
10.5	EW							13.2*	13.2*	11.6*	11.6*	10.3*	10.3*	9.3*	9.3*	7.8	8.5*	6.4	7.8*	5.1	6.8			4.8	6.4	18.4	
9.0	EW							13.5*	13.5*	11.8*	11.8*	10.4*	10.4*	9.4*	9.4*	7.6	8.5*	6.2	7.8*	5.1	6.8			4.4	6.0	19.0	
7.5	EW					16.4*	16.4*	13.9*	13.9*	12.0*	12.0*	10.6*	10.6*	9.0	9.5*	7.4	8.6*	6.1	7.8*	5.0	6.7			4.1	5.6	19.4	
6.0	EW			18.5*	18.5*	17.1*	17.1*	14.3*	14.3*	12.3*	12.3*	10.6	10.8*	8.6	9.6*	7.1	8.7*	5.9	7.7	4.9	6.5	4.1	5.5		3.9	5.4	19.8
4.5	EW			22.6*	22.6*	17.9*	17.9*	14.8*	14.8*	12.5	12.6*	10.0	11.0*	8.2	9.7*	6.8	8.7*	5.6	7.5	4.7	6.4	4.0	5.5		3.8	5.2	20.0
3.0	EW			23.7*	23.7*	18.6*	18.6*	14.7	15.2*	11.6	12.9*	9.4	11.2*	7.7	9.8*	6.4	8.5	5.4	7.3	4.6	6.2	3.9	5.4		3.7	5.1	20.0
1.5	EW			8.9*	8.9*	17.4	19.0*	13.4	15.5*	10.7	13.1*	8.8	11.3*	7.3	9.7	6.1	8.2	5.2	7.0	4.4	6.1	3.8	5.3		3.6	5.0	20.0
0	EW			6.7*	6.7*	16.0	16.4*	12.4	15.6*	10.0	13.1*	8.2	11.1	6.9	9.3	5.8	7.9	5.0	6.8	4.3	5.9	3.7	5.2		3.6	4.9*	19.9
-1.5	EW			6.6*	6.6*	13.0*	13.0*	11.7	15.2*	9.5	12.8*	7.8	10.7	6.6	9.0	5.6	7.7	4.8	6.7	4.2	5.8	3.7	4.5*		3.7	4.4*	19.6
-3.0	EW			7.2*	7.2*	12.3*	12.3*	11.3	14.3*	9.1	12.2*	7.5	10.4	6.4	8.8	5.4	7.5	4.7	6.5	4.1	5.3*				3.9	4.5*	18.7
-4.5	EW					12.5*	12.5*	11.0	12.8*	8.9	11.1*	7.3	9.5*	6.2	8.2*	5.4	6.9*	4.7	5.6*						4.4	5.0*	17.1
-6.0	EW									8.8	9.3*	7.3	8.1*	6.2	6.8*										5.8	6.4*	14.1

Height **Can be slewed through 360°** **In longitudinal position of undercarriage** **Max. reach** * Limited by hydr. capacity

The lift capacities on the stick end without attachment are stated in metric tons (t) and can be slewed through 360° on a firm, level supporting surface. Capacities are valid for 600 mm wide triple grouser pads (resp. flat pads). Indicated loads based on the ISO 10567 standard and do not exceed 75% of tipping or 87% of hydraulic capacity. The lift capacity values indicated are attained at the corresponding operating temperature. This operating temperature is ensured by continuous movement of the boom. Weights of fitted attachments (grabs, load hooks, etc.) and load accommodation attachment are to be deducted from the lift capacity values. The lift capacity of the unit is limited by its stability, the lifting capability of the hydraulic elements, or the maximum permissible lifting capacity of the load hook. In accordance with the harmonised European Standard EN 474-5, hydraulic excavators used for lifting operations must be equipped with pipe fracture safety valves, an overload warning device, a load hook and a lift capacity chart.

LH 80 C SW – Equipment AG20

Industry – Kinematic 2D

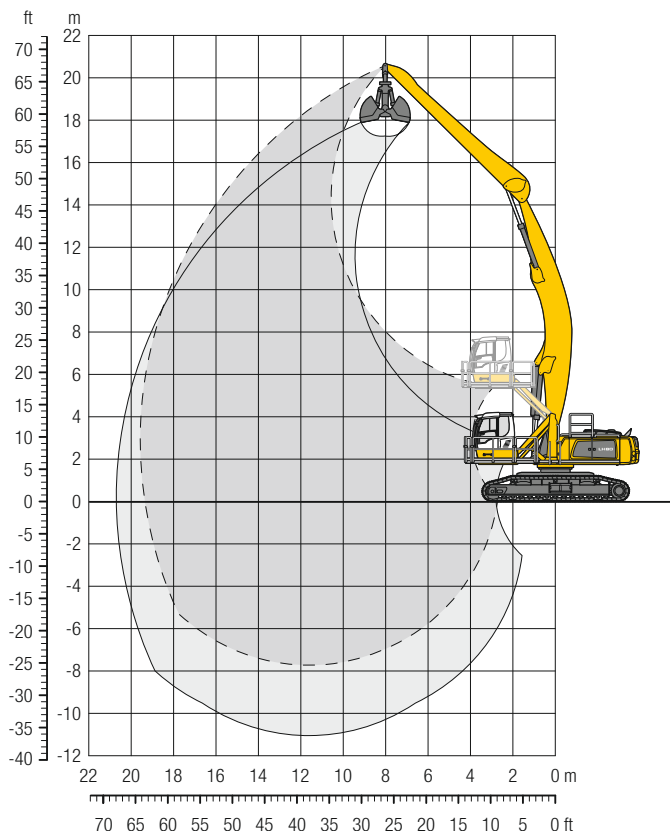

Operating Weight and Ground Pressure

The operating weight includes the basic machine with hydr. cab elevation, angled boom 11.50 m, straight stick 9.00 m and grab for loose material GMZ 80/3.00 m³.

Weight	77,300 kg
Pad width	750 mm
Ground pressure	on request

Dimensions

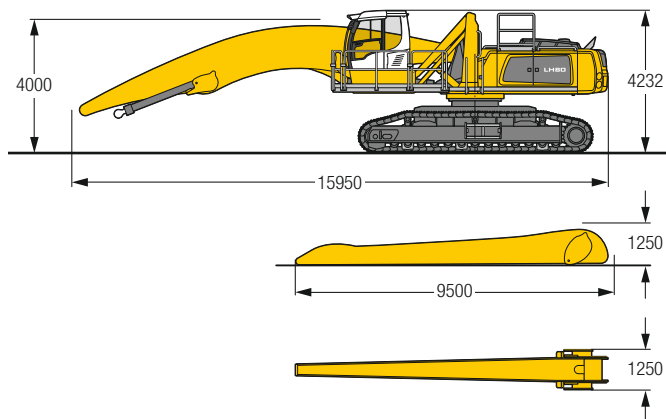

m	Undercarriage	6.0 m		7.5 m		9.0 m		10.5 m		12.0 m		13.5 m		15.0 m		16.5 m		18.0 m		19.5 m		21.0 m		m							
		SW	SW	SW	SW	SW	SW	SW	SW	SW	SW	SW	SW	SW	SW	SW	SW	SW	SW	SW	SW	SW	SW								
21.0	SW																														
19.5	SW																														
18.0	SW					10.7*	10.7*																	8.7*	8.7*	10.4					
16.5	SW							10.7*	10.7*	8.8*	8.8*														8.7*	8.7*	12.5				
15.0	SW									9.7*	9.7*	8.9*	8.9*	8.6*	8.6*											7.3*	7.3*	14.2			
13.5	SW									9.6*	9.6*	8.9*	8.9*	8.3*	8.3*	7.0*	7.0*										6.9*	6.9*	15.5		
12.0	SW									9.7*	9.7*	8.9*	8.9*	8.7*	8.7*	7.8*	7.8*										6.7*	6.7*	16.6		
10.5	SW									10.9*	10.9*	9.9*	9.9*	9.0*	9.0*	8.4*	8.4*	7.9*	7.9*	7.1*	7.1*							6.6*	6.6*	17.5	
9.0	SW																											6.5*	6.5*	18.2	
7.5	SW																											6.7*	6.7*	18.8	
6.0	SW																											6.4	6.6*	19.2	
4.5	SW																											6.1	6.7*	19.5	
3.0	SW																														
1.5	SW																														
0	SW																														
-1.5	SW																														
-3.0	SW																														
-4.5	SW																														
-6.0	SW																														
-7.5	SW																														
-9.0	SW																														

Height
 Can be slewed through 360°
 In longitudinal position of undercarriage
 Max. reach
 * Limited by hydr. capacity

The lift capacities on the stick end without attachment are stated in metric tons (t) and can be slewed through 360° on a firm, level supporting surface. Capacities are valid for 750 mm wide triple grouser pads (resp. flat pads). Indicated loads based on the ISO 10567 standard and do not exceed 75% of tipping or 87% of hydraulic capacity. The lift capacity values indicated are attained at the corresponding operating temperature. This operating temperature is ensured by continuous movement of the boom. Weights of fitted attachments (grabs, load hooks, etc.) and load accommodation attachment are to be deducted from the lift capacity values. The lift capacity of the unit is limited by its stability, the lifting capability of the hydraulic elements, or the maximum permissible lifting capacity of the load hook. In accordance with the harmonised European Standard EN 474-5, hydraulic excavators used for lifting operations must be equipped with pipe fracture safety valves, an overload warning device, a load hook and a lift capacity chart.

LH 80 M HR – Equipment GA22

Industry – Kinematic 2A

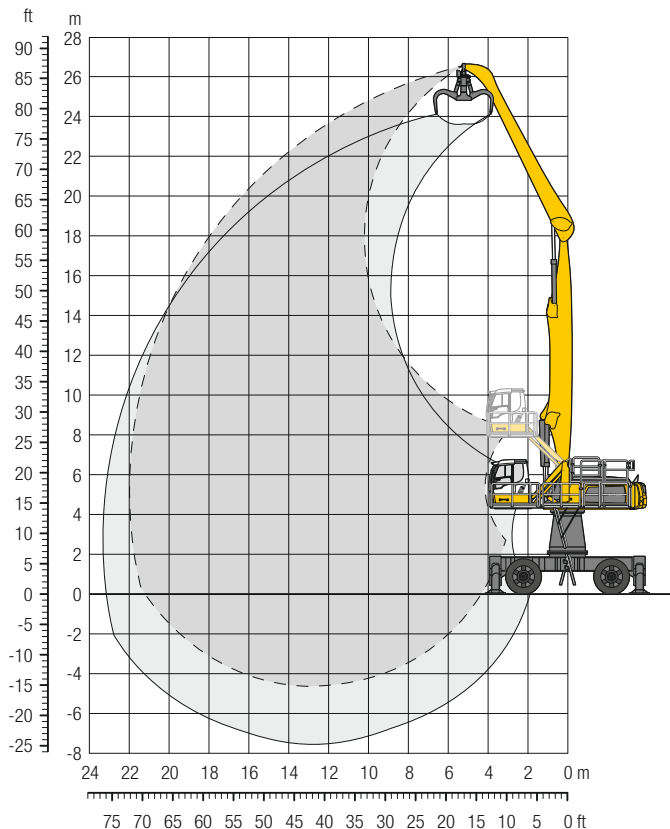

Operating Weight

The operating weight includes the basic machine with 4 point outriggers, turret 2,000 mm, hydr. cab elevation, 4 solid tyres, straight boom 12.50 m, angled stick 10.00 m and multi-tine grab GMM 80-5/1.70 m³ semi-closed tines.

Weight 91,400 kg

Dimensions

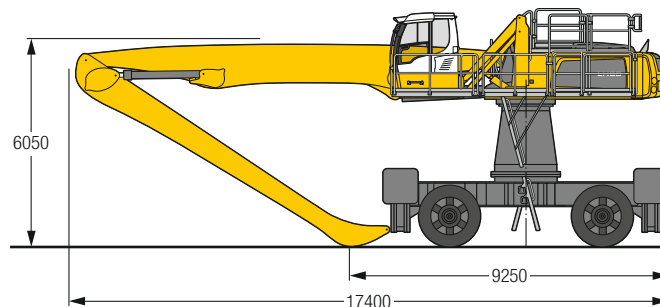

m	6.0 m		7.5 m		9.0 m		10.5 m		12.0 m		13.5 m		15.0 m		16.5 m		18.0 m		19.5 m		21.0 m		m				
	4 pt. outriggers down	4 pt. outriggers down	4 pt. outriggers down	4 pt. outriggers down	4 pt. outriggers down	4 pt. outriggers down	4 pt. outriggers down	4 pt. outriggers down	4 pt. outriggers down	4 pt. outriggers down	4 pt. outriggers down	4 pt. outriggers down	4 pt. outriggers down	4 pt. outriggers down	4 pt. outriggers down	4 pt. outriggers down	4 pt. outriggers down	4 pt. outriggers down	4 pt. outriggers down	4 pt. outriggers down	4 pt. outriggers down	4 pt. outriggers down					
25.5			11.1*	11.1*																			10.1*	10.1*	8.3		
24.0					11.0*	11.0*	9.5*	9.5*																8.3*	8.3*	11.3	
22.5							10.8*	10.8*	9.5*	9.5*	7.4*	7.4*												7.3*	7.3*	13.5	
21.0							11.4*	11.4*	10.6*	10.6*	9.3*	9.3*	7.3*	7.3*										6.7*	6.7*	15.3	
19.5							11.8*	11.8*	10.8*	10.8*	9.7*	9.7*	8.9*	8.9*	6.8*	6.8*									6.4*	6.4*	16.7
18.0							12.1*	12.1*	10.8*	10.8*	9.7*	9.7*	8.8*	8.8*	8.0*	8.0*	8.1*	8.1*							6.1*	6.1*	17.9
16.5							12.1*	12.1*	10.8*	10.8*	9.7*	9.7*	8.8*	8.8*	8.0*	8.0*	7.4*	7.4*							5.9*	5.9*	18.9
15.0							12.2*	12.2*	10.8*	10.8*	9.7*	9.7*	8.8*	8.8*	8.0*	8.0*	7.4*	7.4*	6.2*	6.2*					5.7*	5.7*	19.7
13.5							12.3*	12.3*	10.9*	10.9*	9.7*	9.7*	8.8*	8.8*	8.0*	8.0*	7.3*	7.3*	6.7*	6.7*					5.7*	5.7*	20.4
12.0							12.3*	12.3*	10.9*	10.9*	9.7*	9.7*	8.9*	8.9*	8.1*	8.1*	7.4*	7.4*	6.7*	6.7*					5.6*	5.6*	20.9
10.5							13.4*	13.4*	14.8*	14.8*	12.7*	12.7*	11.2*	11.2*	9.9*	9.9*	8.9*	8.9*	8.1*	8.1*	7.4*	7.4*	6.7*	6.7*	6.0*	6.0*	21.3
9.0							13.8*	13.8*	16.6*	16.6*	15.2*	15.2*	13.0*	13.0*	11.3*	11.3*	10.0*	10.0*	9.0*	9.0*	8.1*	8.1*	7.4*	7.4*	6.7*	6.7*	21.7
7.5							23.9*	23.9*	18.9*	18.9*	15.6*	15.6*	13.3*	13.3*	11.5*	11.5*	10.2*	10.2*	9.1*	9.1*	8.2*	8.2*	7.4*	7.4*	6.6*	6.6*	21.9
6.0							24.9*	24.9*	19.5*	19.5*	16.0*	16.0*	13.5*	13.5*	11.7*	11.7*	10.2*	10.2*	9.1*	9.1*	8.2*	8.2*	7.3*	7.3*	6.6*	6.6*	22.0
4.5							7.3*	7.3*	19.8*	19.8*	16.2*	16.2*	13.6*	13.6*	11.8*	11.8*	10.3*	10.3*	9.1*	9.1*	8.1*	8.1*	7.2*	7.2*	6.4*	6.4*	22.0
3.0							4.9*	4.9*	12.7*	12.7*	16.2*	16.2*	13.7*	13.7*	11.7*	11.7*	10.2*	10.2*	9.0*	9.0*	8.0*	8.0*	7.1*	7.1*	6.2*	6.2*	21.9
1.5							4.6*	4.6*	9.6*	9.6*	15.9*	15.9*	13.5*	13.5*	11.6*	11.6*	10.1*	10.1*	8.8*	8.8*	7.8*	7.8*	6.8*	6.8*	5.9*	5.9*	21.6
0							5.1*	5.1*	8.9*	8.9*	15.2*	15.2*	12.9*	12.9*	11.1*	11.1*	9.7*	9.7*	8.5*	8.5*	7.4*	7.4*	6.4*	6.4*	5.3*	5.3*	21.2
-1.5							5.8*	5.8*	9.1*	9.1*	13.9*	13.9*	12.0*	12.0*	10.4*	10.4*	9.1*	9.1*	7.9*	7.9*	6.8*	6.8*	5.7*	5.7*	4.5*	4.5*	20.1
-3.0									9.6*	9.6*	12.1*	12.1*	10.7*	10.7*	9.3*	9.3*	8.1*	8.1*	7.0*	7.0*	5.9*	5.9*	4.7*	4.7*			18.3
-4.5											7.7*	7.7*	6.7*	6.7*											4.4*	4.4*	14.7

Height **Can be slewed through 360°** **In longitudinal position of undercarriage** **Max. reach** * Limited by hydr. capacity

The lift capacities on the stick end without attachment are stated in metric tons (t) and are valid on a firm, level supporting surface with blocked oscillating axle. These capacities can be slewed through 360° with the undercarriage in the transverse position. Capacities in the longitudinal position of the undercarriage (+/- 15°) are specified over the rigid axle with the stabilizers down. Indicated loads based on the ISO 10567 standard and do not exceed 75% of tipping or 87% of hydraulic capacity. The lift capacity values indicated are attained at the corresponding operating temperature. This operating temperature is ensured by continuous movement of the boom. Weights of fitted attachments (grabs, load hooks, etc.) and load accommodation attachment are to be deducted from the lift capacity values. The lift capacity of the unit is limited by its stability, the lifting capability of the hydraulic elements, or the maximum permissible lifting capacity of the load hook.

In accordance with the harmonised European Standard EN 474-5, hydraulic excavators used for lifting operations must be equipped with pipe fracture safety valves, an overload warning device, a load hook and a lift capacity chart.

LH 80 M HR – Equipment AG22

Industry – Kinematic 2D

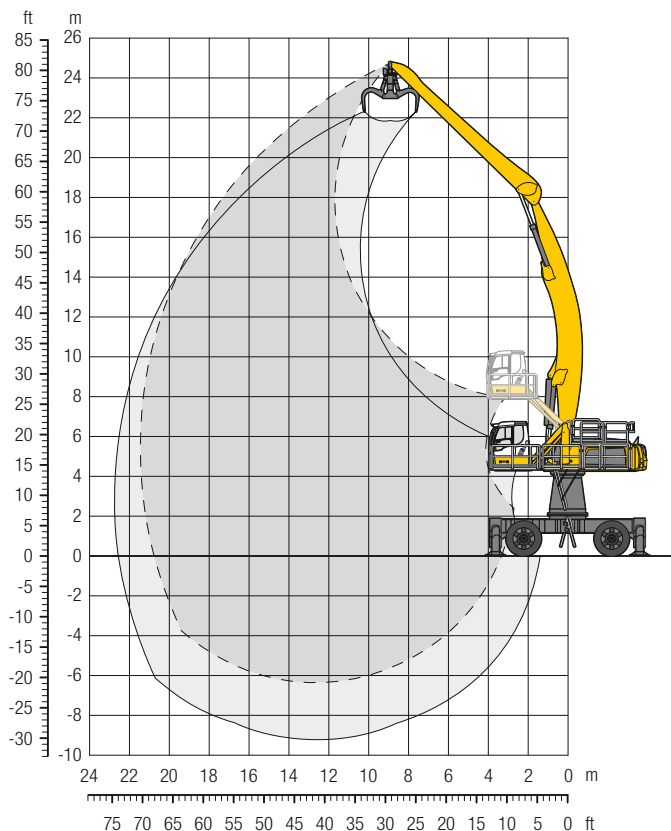

Operating Weight

The operating weight includes the basic machine with 4 point outriggers, turret 2,000 mm, hydr. cab elevation, 4 solid tyres, angled boom 12.50 m, straight stick 10.00 m and multi-tine grab GMM 80-5/1.40 m³ semi-closed tines.

Weight 91,800 kg

Dimensions

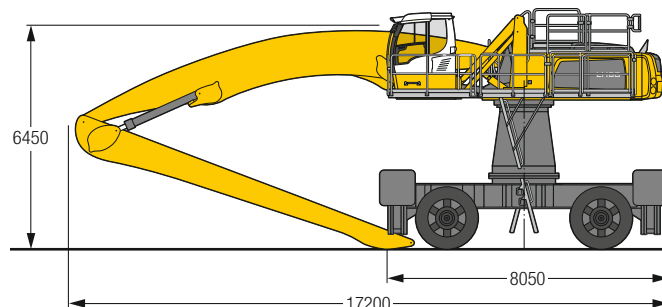

m	6.0 m		7.5 m		9.0 m		10.5 m		12.0 m		13.5 m		15.0 m		16.5 m		18.0 m		19.5 m		21.0 m		m			
	4 pt. outriggers down	4 pt. outriggers down	4 pt. outriggers down	4 pt. outriggers down	4 pt. outriggers down	4 pt. outriggers down	4 pt. outriggers down	4 pt. outriggers down	4 pt. outriggers down	4 pt. outriggers down	4 pt. outriggers down	4 pt. outriggers down	4 pt. outriggers down	4 pt. outriggers down	4 pt. outriggers down	4 pt. outriggers down	4 pt. outriggers down	4 pt. outriggers down	4 pt. outriggers down	4 pt. outriggers down	4 pt. outriggers down	4 pt. outriggers down				
24.0																							7.8*	7.8*	10.2	
22.5									7.8*	7.8*														7.0*	7.0*	12.6
21.0									9.2*	9.2*	7.8*	7.8*												6.5*	6.5*	14.5
19.5									9.0*	9.0*	8.2*	8.2*	7.6*	7.6*										6.1*	6.1*	16.0
18.0									9.0*	9.0*	8.2*	8.2*	7.5*	7.5*	7.0*	7.0*								5.9*	5.9*	17.2
16.5									9.0*	9.0*	8.1*	8.1*	7.5*	7.5*	6.9*	6.9*	6.2*	6.2*						5.8*	5.8*	18.2
15.0									9.0*	9.0*	8.2*	8.2*	7.5*	7.5*	6.9*	6.9*	6.5*	6.5*						5.7*	5.7*	19.1
13.5									9.2*	9.2*	8.3*	8.3*	7.6*	7.6*	7.0*	7.0*	6.5*	6.5*	6.1*	6.1*				5.6*	5.6*	19.8
12.0							10.5*	10.5*	9.3*	9.3*	8.4*	8.4*	7.7*	7.7*	7.0*	7.0*	6.5*	6.5*	6.1*	6.1*				5.6*	5.6*	20.3
10.5						12.4*	12.4*	10.8*	10.8*	9.5*	9.5*	8.6*	8.6*	7.8*	7.8*	7.1*	7.1*	6.6*	6.6*	6.1*	6.1*			5.7*	5.7*	20.8
9.0					15.4*	15.4*	12.9*	12.9*	11.1*	11.1*	9.8*	9.8*	8.8*	8.8*	7.9*	7.9*	7.2*	7.2*	6.7*	6.7*			5.8*	5.8*	21.1	
7.5			20.5*	20.5*	16.3*	16.3*	13.5*	13.5*	11.5*	11.5*	10.1*	10.1*	9.0*	9.0*	8.1*	8.1*	7.3*	7.3*	6.7*	6.7*	6.2*	6.2*	5.8*	5.8*	21.3	
6.0			22.0*	22.0*	17.2*	17.2*	14.1*	14.1*	11.9*	11.9*	10.4*	10.4*	9.2*	9.2*	8.2*	8.2*	7.5*	7.5*	6.8*	6.8*	6.3*	6.3*	5.8*	5.8*	21.4	
4.5			10.8*	10.8*	18.0*	18.0*	14.6*	14.6*	12.3*	12.3*	10.7*	10.7*	9.4*	9.4*	8.4*	8.4*	7.6*	7.6*	6.9*	6.9*	6.3*	6.3*	5.8*	5.8*	21.4	
3.0			7.0*	7.0*	15.7*	15.7*	15.1*	15.1*	12.7*	12.7*	10.9*	10.9*	9.6*	9.6*	8.5*	8.5*	7.7*	7.7*	7.0*	7.0*	6.3*	6.3*	5.7*	5.7*	21.3	
1.5			6.3*	6.3*	11.6*	11.6*	15.4*	15.4*	12.9*	12.9*	11.1*	11.1*	9.7*	9.7*	8.6*	8.6*	7.7*	7.7*	7.0*	7.0*	6.3*	6.3*	5.5*	5.5*	21.1	
0			6.4*	6.4*	10.4*	10.4*	15.5*	15.5*	13.0*	13.0*	11.2*	11.2*	9.8*	9.8*	8.6*	8.6*	7.7*	7.7*	6.9*	6.9*	6.1*	6.1*			20.8	
-1.5			6.8*	6.8*	10.1*	10.1*	15.2*	15.2*	12.9*	12.9*	11.1*	11.1*	9.7*	9.7*	8.5*	8.5*	7.5*	7.5*	6.7*	6.7*	5.8*	5.8*			20.3	
-3.0			7.4*	7.4*	10.3*	10.3*	14.6*	14.6*	12.5*	12.5*	10.8*	10.8*	9.4*	9.4*	8.2*	8.2*	7.2*	7.2*	6.3*	6.3*	5.2*	5.2*			19.7	
-4.5					10.8*	10.8*	13.5*	13.5*			11.7*	11.7*	10.1*	10.1*	8.8*	8.8*	7.7*	7.7*	6.7*	6.7*			5.1*	5.1*	18.6	
-6.0									10.4*	10.4*	9.1*	9.1*	7.9*	7.9*	6.8*	6.8*							6.3*	6.3*	15.7	

Height Can be slewed through 360° In longitudinal position of undercarriage Max. reach * Limited by hydr. capacity

The lift capacities on the stick end without attachment are stated in metric tons (t) and are valid on a firm, level supporting surface with blocked oscillating axle. These capacities can be slewed through 360° with the undercarriage in the transverse position. Capacities in the longitudinal position of the undercarriage (+/- 15°) are specified over the rigid axle with the stabilizers down. Indicated loads based on the ISO 10567 standard and do not exceed 75% of tipping or 87% of hydraulic capacity. The lift capacity values indicated are attained at the corresponding operating temperature. This operating temperature is ensured by continuous movement of the boom. Weights of fitted attachments (grabs, load hooks, etc.) and load accommodation attachment are to be deducted from the lift capacity values. The lift capacity of the unit is limited by its stability, the lifting capability of the hydraulic elements, or the maximum permissible lifting capacity of the load hook.

In accordance with the harmonised European Standard EN 474-5, hydraulic excavators used for lifting operations must be equipped with pipe fracture safety valves, an overload warning device, a load hook and a lift capacity chart.

LH 80 C HR – Equipment GA21

Industry – Kinematic 2A

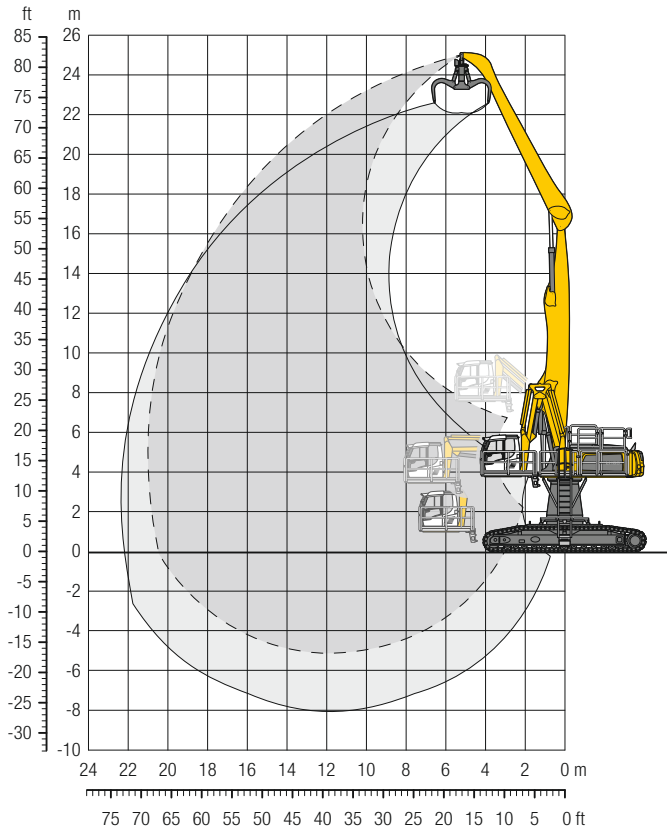

Operating Weight and Ground Pressure

The operating weight includes the basic machine with turret 2,000 mm, hydr. cab elevation, straight boom 11.50 m, angled stick 10.00 m and multi-tine grab GMM 80-5/1.70 m³ semi-closed tines.

Weight	94,400 kg
Pad width	750 mm
Ground pressure	on request

Dimensions

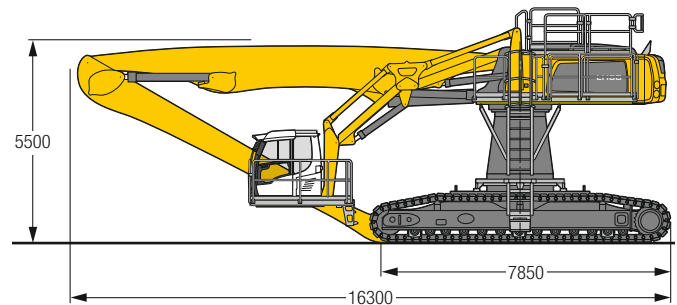

m	Undercarriage	6.0 m		7.5 m		9.0 m		10.5 m		12.0 m		13.5 m		15.0 m		16.5 m		18.0 m		19.5 m		21.0 m		m		
		SW	SW	SW	SW	SW	SW	SW	SW	SW	SW	SW	SW	SW	SW	SW	SW	SW	SW	SW	SW	SW	SW			
24.0	SW			11.1*	11.1*																			9.9*	9.9*	8.3
22.5	SW					11.0*	11.0*	9.3*	9.3*															8.2*	8.2*	11.2
21.0	SW							10.7*	10.7*	9.3*	9.3*													7.3*	7.3*	13.3
19.5	SW							11.4*	11.4*	10.5*	10.5*	9.0*	9.0*											6.7*	6.7*	15.0
18.0	SW							11.8*	11.8*	11.0*	11.0*	10.1*	10.1*	8.6*	8.6*									6.3*	6.3*	16.3
16.5	SW							12.1*	12.1*	11.0*	11.0*	10.0*	10.0*	9.2*	9.2*	7.9*	7.9*							6.0*	6.0*	17.4
15.0	SW							12.2*	12.2*	11.0*	11.0*	10.0*	10.0*	9.1*	9.1*	8.5*	8.5*	6.7*	6.7*					5.8*	5.8*	18.4
13.5	SW							12.3*	12.3*	11.0*	11.0*	10.0*	10.0*	9.2*	9.2*	8.5*	8.5*							5.7*	5.7*	19.1
12.0	SW							12.5*	12.5*	11.2*	11.2*	10.1*	10.1*	9.2*	9.2*	8.5*	8.5*	7.8*	7.8*	6.3*	6.3*			5.6*	5.6*	19.7
10.5	SW							12.8*	12.8*	11.4*	11.4*	10.2*	10.2*	9.3*	9.3*	8.5*	8.5*	7.8*	7.8*	7.2*	7.2*			5.6*	5.6*	20.2
9.0	SW							13.1*	13.1*	11.6*	11.6*	10.4*	10.4*	9.4*	9.4*	8.6*	8.6*	7.9*	7.9*	7.2*	7.2*			5.6*	5.6*	20.6
7.5	SW							13.5*	13.5*	15.1*	15.1*	13.1*	13.1*	11.6*	11.6*	10.4*	10.4*	9.4*	9.4*	7.9*	7.9*	7.1*	7.1*			20.8
6.0	SW							14.3*	14.3*	17.2*	17.2*	15.6*	15.6*	13.5*	13.5*	11.9*	11.9*	10.6*	10.6*	9.5*	9.5*	8.6*	8.6*	7.9*	7.9*	21.0
4.5	SW							24.7*	24.7*	19.6*	19.6*	16.2*	16.2*	13.9*	13.9*	12.1*	12.1*	10.7*	10.7*	9.6*	9.6*	8.7*	8.7*	7.9*	7.9*	21.0
3.0	SW							26.1*	26.1*	20.4*	20.4*	16.8*	16.8*	14.2*	14.2*	12.3*	12.3*	10.9*	10.9*	9.7*	9.7*	8.7*	8.7*	7.8*	7.8*	21.0
1.5	SW							11.2*	11.2*	21.0*	21.0*	17.1*	17.1*	14.5*	14.5*	12.5*	12.5*	10.9*	10.9*	9.7*	9.7*	8.6*	8.6*	7.7*	7.7*	20.9
0	SW							7.7*	7.7*	18.8*	18.8*	17.2*	17.2*	14.5*	14.5*	12.5*	12.5*	10.9*	10.9*	9.6*	9.6*	8.5*	8.5*	7.4*	7.4*	20.7
-1.5	SW							7.2*	7.2*	14.0*	14.0*	16.9*	16.9*	14.3*	14.3*	12.3*	12.3*	10.7*	10.7*	9.3*	9.3*	8.1*	8.1*	7.0*	7.0*	20.4
-3.0	SW							7.5*	7.5*	12.7*	12.7*	16.1*	16.1*	13.6*	13.6*	11.7*	11.7*	10.1*	10.1*	8.8*	8.8*	7.5*	7.5*	6.2*	6.2*	19.5
-4.5	SW							8.2*	8.2*	12.7*	12.7*	14.6*	14.6*	12.5*	12.5*	10.8*	10.8*	9.3*	9.3*	7.9*	7.9*	6.6*	6.6*			17.9
-6.0	SW									12.3*	12.3*	10.7*	10.7*	9.3*	9.3*	7.9*	7.9*	6.6*	6.6*					6.3*	6.3*	15.3

Height
 Can be slewed through 360°
 In longitudinal position of undercarriage
 Max. reach
 * Limited by hydr. capacity

The lift capacities on the stick end without attachment are stated in metric tons (t) and can be slewed through 360° on a firm, level supporting surface. Capacities are valid for 750 mm wide flat pads. Indicated loads based on the ISO 10567 standard and do not exceed 75% of tipping or 87% of hydraulic capacity. The lift capacity values indicated are attained at the corresponding operating temperature. This operating temperature is ensured by continuous movement of the boom. Weights of fitted attachments (grabs, load hooks, etc.) and load accommodation attachment are to be deducted from the lift capacity values. The lift capacity of the unit is limited by its stability, the lifting capability of the hydraulic elements, or the maximum permissible lifting capacity of the load hook. In accordance with the harmonised European Standard EN 474-5, hydraulic excavators used for lifting operations must be equipped with pipe fracture safety valves, an overload warning device, a load hook and a lift capacity chart.

LH 80 C Gantry – Equipment AG22

Industry – Kinematic 2C

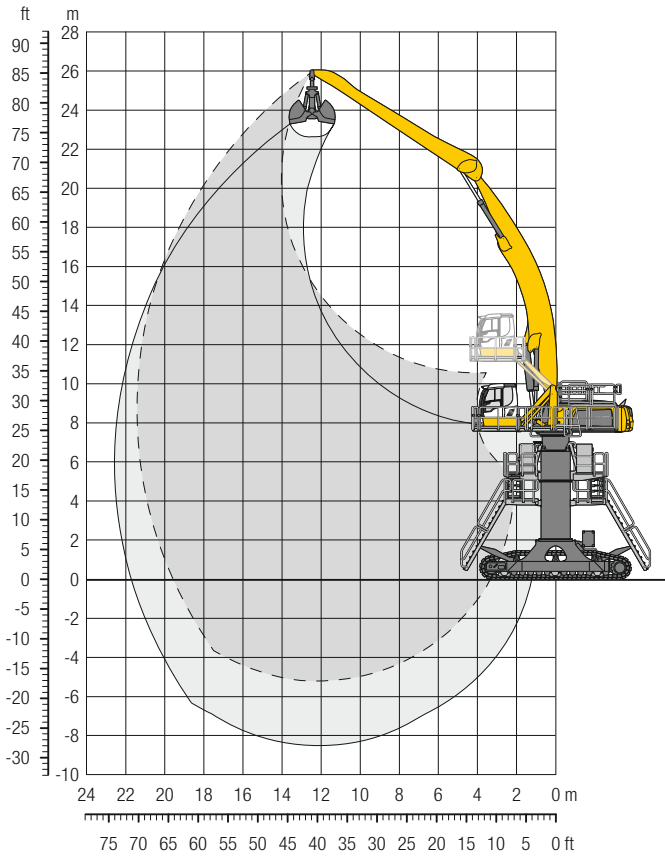

Operating Weight and Ground Pressure

The operating weight includes the basic machine with hydr. cab elevation, angled boom 12.50 m, straight stick 10.00 m and grab for loose material GMZ 80/3.00 m³.

Weight	112,500 kg
Pad width	750 mm
Ground pressure	on request

Dimensions

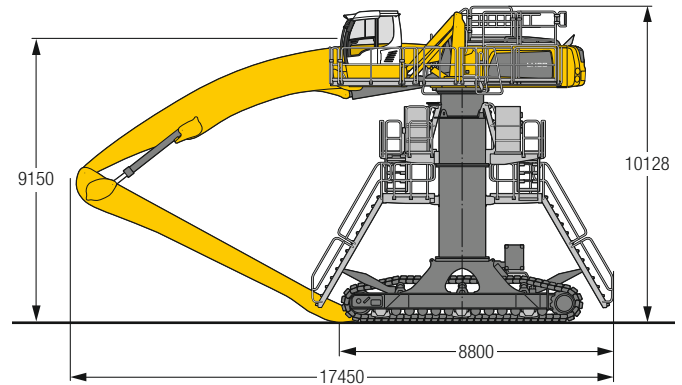

m	Gantry	6.0 m		7.5 m		9.0 m		10.5 m		12.0 m		13.5 m		15.0 m		16.5 m		18.0 m		19.5 m		21.0 m		m			
		Can be slewed through 360°	In longitudinal position of undercarriage	Can be slewed through 360°	In longitudinal position of undercarriage	Can be slewed through 360°	In longitudinal position of undercarriage	Can be slewed through 360°	In longitudinal position of undercarriage	Can be slewed through 360°	In longitudinal position of undercarriage	Can be slewed through 360°	In longitudinal position of undercarriage	Can be slewed through 360°	In longitudinal position of undercarriage	Can be slewed through 360°	In longitudinal position of undercarriage	Can be slewed through 360°	In longitudinal position of undercarriage	Can be slewed through 360°	In longitudinal position of undercarriage	Can be slewed through 360°	In longitudinal position of undercarriage	Can be slewed through 360°	In longitudinal position of undercarriage		
25.5	Gantry											7.4*	7.4*											6.8*	6.8*	13.1	
24.0	Gantry																								6.4*	6.4*	14.8
22.5	Gantry																								6.1*	6.1*	16.3
21.0	Gantry																								5.9*	5.9*	17.5
19.5	Gantry																								5.7*	5.7*	18.4
18.0	Gantry																								5.7*	5.7*	19.3
16.5	Gantry																								5.6*	5.6*	19.9
15.0	Gantry																								5.5*	5.5*	20.5
13.5	Gantry																								5.5*	5.5*	20.9
12.0	Gantry																								5.4*	5.4*	21.2
10.5	Gantry	18.9*	18.9*	14.9*	14.9*	12.4*	12.4*	10.6*	10.6*	9.3*	9.3*	8.3*	8.3*	7.5*	7.5*	6.8*	6.8*	6.3*	6.3*	5.9*	5.9*	5.5*	5.5*	5.4*	5.4*	21.3	
9.0	Gantry	20.5*	20.5*	15.9*	15.9*	13.0*	13.0*	11.1*	11.1*	9.6*	9.6*	8.5*	8.5*	7.7*	7.7*	7.0*	7.0*	6.4*	6.4*	6.0*	6.0*	5.5*	5.5*	5.4*	5.4*	21.4	
7.5	Gantry	9.3*	9.3*	16.9*	16.9*	13.7*	13.7*	11.6*	11.6*	10.0*	10.0*	8.8*	8.8*	7.9*	7.9*	7.2*	7.2*	6.5*	6.5*	6.0*	6.0*	5.6*	5.6*	5.4*	5.4*	21.4	
6.0	Gantry	6.7*	6.7*	14.2*	14.2*	14.3*	14.3*	12.0*	12.0*	10.3*	10.3*	9.1*	9.1*	8.1*	8.1*	7.3*	7.3*	6.6*	6.6*	6.1*	6.1*	5.5*	5.5*	5.4*	5.4*	21.3	
4.5	Gantry	6.2*	6.2*	11.2*	11.2*	14.7*	14.7*	12.3*	12.3*	10.6*	10.6*	9.3*	9.3*	8.2*	8.2*	7.4*	7.4*	6.7*	6.7*	6.1*	6.1*	5.5*	5.5*	5.4*	5.4*	21.0	
3.0	Gantry	6.5*	6.5*	10.2*	10.2*	15.0*	15.0*	12.6*	12.6*	10.8*	10.8*	9.4*	9.4*	8.3*	8.3*	7.5*	7.5*	6.7*	6.7*	6.0*	6.0*	5.4*	5.4*	5.4*	5.4*	20.7	
1.5	Gantry	7.0*	7.0*	10.1*	10.1*	14.9*	14.9*	12.6*	12.6*	10.8*	10.8*	9.4*	9.4*	8.3*	8.3*	7.4*	7.4*	6.6*	6.6*	5.8*	5.8*	5.4*	5.4*	5.4*	5.4*	20.2	
0	Gantry	7.6*	7.6*	10.4*	10.4*	14.5*	14.5*	12.3*	12.3*	10.6*	10.6*	9.3*	9.3*	8.1*	8.1*	7.2*	7.2*	6.3*	6.3*	5.3*	5.3*	5.2*	5.2*	5.2*	5.2*	19.6	
-1.5	Gantry	8.3*	8.3*	11.0*	11.0*	13.6*	13.6*	11.7*	11.7*	10.1*	10.1*	8.8*	8.8*	7.7*	7.7*	6.7*	6.7*	5.7*	5.7*	5.0*	5.0*	5.0*	5.0*	5.0*	5.0*	18.8	
-3.0	Gantry	9.0*	9.0*	11.7*	11.7*	12.2*	12.2*	10.7*	10.7*	9.3*	9.3*	8.1*	8.1*	7.0*	7.0*	5.9*	5.9*			4.6*	4.6*	4.6*	4.6*	4.6*	4.6*	17.9	
-4.5	Gantry			10.3*	10.3*	9.1*	9.1*	7.9*	7.9*	6.8*	6.8*	5.7*	5.7*							5.0*	5.0*	5.0*	5.0*	5.0*	5.0*	15.8	

Height **Can be slewed through 360°** **In longitudinal position of undercarriage** **Max. reach** * Limited by hydr. capacity

The lift capacities on the stick end without attachment are stated in metric tons (t) and can be slewed through 360° on a firm, level supporting surface. Capacities are valid for 750 mm wide flat pads. Indicated loads based on the ISO 10567 standard and do not exceed 75% of tipping or 87% of hydraulic capacity. The lift capacity values indicated are attained at the corresponding operating temperature. This operating temperature is ensured by continuous movement of the boom. Weights of fitted attachments (grabs, load hooks, etc.) and load accommodation attachment are to be deducted from the lift capacity values. The lift capacity of the unit is limited by its stability, the lifting capability of the hydraulic elements, or the maximum permissible lifting capacity of the load hook.

In accordance with the harmonised European Standard EN 474-5, hydraulic excavators used for lifting operations must be equipped with pipe fracture safety valves, an overload warning device, a load hook and a lift capacity chart.

Liebherr ERC-System



ERC System – More Performance, Less Consumption

Lowering the equipment stores energy in the ERC system. This stored energy is then made available to the machine to provide additional engine power. When the equipment is raised the stored energy is released and is reflected in

powerful, homogeneous operating cycles. The result is a clear saving on fuel – and, at the same time, even greater performance.

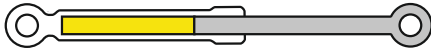

B 1. Equipment fitting raised/
Energy released



2. Lower equipment fitting/Store energy
4. Raise equipment fitting/Release energy



A 3. Equipment fitting lowered/
Energy stored

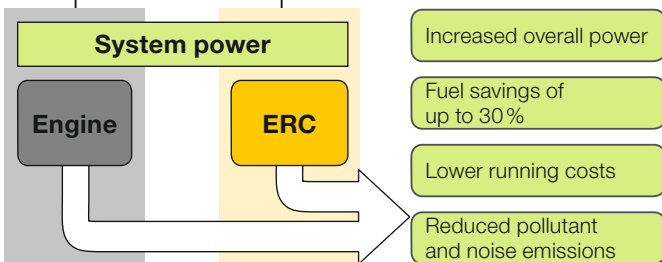

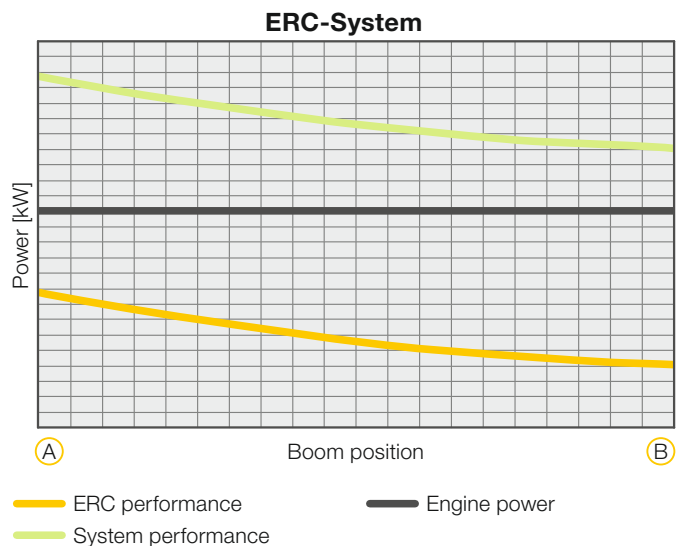

System Power

The energy recovery cylinder is a storage system which is independent of the diesel engine. The system performance of material handling machines fitted with the ERC system is composed of the installed engine power and the energy recovery cylinder. When the equipment is raised, energy from the ERC system is supplied in addition to the power from the diesel engine.



Equipment

	80 M	80 C	80 M HR	80 C HR	80 C Gantry
 Undercarriage					
Track pads, variants		+		+	+
Individual control outriggers	+		•		
Three-piece chain guide		•		•	•
Shuttle axle lock, automatic	•		•		
Outrigger monitoring system	+		+		
Tyres, variants	+		+		
Protection for piston rods, outriggers	+		+		
Two lockable storage compartments	•				
Undercarriage, variants		+			

	80 M	80 C	80 M HR	80 C HR	80 C Gantry
 Uppercarriage					
Uppercarriage right side light, 1 piece, LED	•	•	•	•	•
Uppercarriage rear light, 2 pieces, LED	+	+			
Uppercarriage underneath rear light, 1 piece, LED			+	+	+
Refuelling system with filling pump	+	+	+	+	+
Railing on uppercarriage	+	+	•	•	•
Generator	+	+	+	+	+
Main battery switch for electrical system	•	•	•	•	•
Amber beacon, at uppercarriage, LED double flash	+	+	+	+	+
Protection for headlights	+	+			
Protection for rear lights	+	+			
Tool equipment, extended	•	•	•	•	•

	80 M	80 C	80 M HR	80 C HR	80 C Gantry
 Hydraulic System					
Electronic pump regulation	•	•	•	•	•
Liebherr hydraulic oil from -20 °C to +40 °C	•	•	•	•	•
Liebherr hydraulic oil, biologically degradable	+	+	+	+	+
Liebherr hydraulic oil, specially for warm or cold regions	+	+	+	+	+
Magnetic rod in hydraulic tank	•	•	•	•	•
Bypass filter	+	+	+	+	+
Preheating hydraulic oil	+	+	+	+	+

	80 M	80 C	80 M HR	80 C HR	80 C Gantry
 Engine					
Fuel anti-theft device	+	+	+	+	+
Air pre-filter with dust discharge	+	+	+	+	+
Automatic engine shut-down (time adjustable)	+	+	+	+	+
Preheating fuel	+	+	+	+	+
Preheating coolant	+	+	+	+	+
Preheating engine oil*	+	+	+	+	+

	80 M	80 C	80 M HR	80 C HR	80 C Gantry
 Cooling System					
Reversible fan drive, fully automatic	+	+	+	+	+
Protective grid in front of cooler intake	•	•	•	•	•



Operator's Cab

	80 M	80 C	80 M HR	80 C HR	80 C Gantry
Stabilizer assistant	+		+		
Stabilizer, control lever, left console	+		+		
Stabilizer, proportional control on left joystick	•		•		
Cab lights rear, halogen	+	+	+	+	+
Cab lights rear, LED	+	+	+	+	+
Cab lights front, halogen	+	+	+	+	+
Cab lights front, halogen (under rain cover)	•	•	•	•	•
Cab lights front, LED	+	+	+	+	+
Cab lights front, LED (under rain cover)	+	+	+	+	+
Armrest adjustable	•	•	•	•	•
Circular bubble level	+	+	•	•	•
Slewing gear brake Comfort, button on the left or right joystick	+	+	+	+	+
Driver profile, personalised (max. 5 drivers)	+	+	+	+	+
Operator's seat Comfort	•	•	•	•	•
Operator's seat Premium	+	+	+	+	+
Driving alarm (acoustic signal is emitted during travel, can be switched ON/OFF)	+	+	+	+	+
Fire extinguisher	+	+	+	+	+
Footrest	+	+	+	+	+
Horn, button on left joystick	•	•	•	•	•
Joystick steering	•		•		
Joystick and wheel steering (slim version)	+		+		
Cab elevation, hydraulic (LHC)	•	•	•	•	•
Cab elevation, hydraulic with double parallelogram (LHC-D)			+	+	+
Cab elevation, rigid (LFC)	+	+			
Automatic air conditioning	•	•	•	•	•
Wheel steering (slim version)	+		+		
LiDAT, vehicle fleet management	•	•	•	•	•
Proportional control	•	•	•	•	•
Radio Comfort, control via display with handsfree set	+	+	+	+	+
Preparation for radio installation	•	•	•	•	•
Back-up alarm (acoustic signal is emitted traveling backward, can not be switched off)	+		+		
Amber beacon, on cabin, LED double flash	+	+	+	+	+
Windows made from impact-resistant laminated safety glass	+	+	•	•	•
Windscreen wiper, roof	+	+	+	+	+
Windshield wiper, entire windscreen	•	•	•	•	•
Top guard	+	+	+	+	+
Front guard, adjustable	+	+	+	+	+
Sun visor	+	+	+	+	+
Left control console, folding	•	•	•	•	•



Equipment

	80 M	80 C	80 M HR	80 C HR	80 C Gantry
Boom lights, 2 pieces, halogen	•	•	•	•	•
Boom lights, 2 pieces, LED	+	+	+	+	+
Stick lights, 2 pieces, halogen	•	•	•	•	•
Stick lights, 2 pieces, LED	+	+	+	+	+
Boom shutoff (retract/extend), electronically	+	+	•	•	•
Equipment with electro-hydraulic end position control	•	•	•	•	•
AutoLift	+	+	+	+	+
Pressure warning mechanism hoist cylinder	•	•	•	•	•
ERC system	•	•	•	•	•
Filter system for attachment	+	+	+	+	+
Electronic lift limitation	+	+	+	+	+
Boom cylinder cushioning	•	•	•	•	•
Stick camera (with separate monitor), bottom side, with protection	+	+	+	+	+
Load torque limitation	+	+	+	+	+
Liebherr multi coupling system	+	+	+	+	+
Pipe fracture safety valves hoist cylinders	•	•	•	•	•
Pipe fracture safety valves stick cylinders	•	•	•	•	•
Quick coupling system MH 110B	+	+	+	+	+
Protection for piston rod, energy recovering cylinder	+	+	+	+	+
Protection for piston rods, hoist cylinder	+	+	+	+	+
Stick shutoff (retract), electronically	•	•	•	•	•
Stick shutoff (retract/extend), electronically	+	+	+	+	+
Retract stick without pressure	•	•	•	•	•
Sticks with quick coupling	+	+	+	+	+
Overload warning device	+	+	+	+	+



Complete Machine

	80 M	80 C	80 M HR	80 C HR	80 C Gantry
Lubrication					
Lubrication undercarriage, manually – decentralised (grease points)	•				
Lubrication undercarriage, manually – centralised (one grease point)	+		•		
Central lubrication system for uppercarriage and equipment, automatically	•	•	•	•	•
Central lubrication system for undercarriage, automatically	+		+		
Central lubrication system, extension for attachment	+	+	+	+	+
Special coating					
Special coating, variants	+	+	+	+	+
Monitoring					
Rear view monitoring with camera	•	•	•	•	•
Side view monitoring with camera	•	•	•	•	•

• = Standard, + = Option

* = country-dependent

Options and/or special equipments, supplied by vendors other than Liebherr, are only to be installed with the knowledge and approval of Liebherr in order to retain warranty.

Attachments

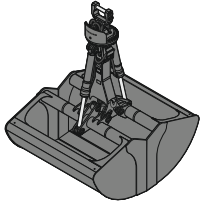

Grab for Loose Material

Shells for loose material with cutting edge (without teeth)

Grab model GMZ 50							
Width of shells	mm	1,400	1,600	1,800	2,000	2,200	2,400
Capacity	m ³	3.50	4.00	4.50	5.00	5.50	6.00
Weight	kg	2,615	2,745	2,820	2,955	3,085	3,215
Grab model GMZ 80							
Width of shells	mm	1,300	1,500	1,750	2,000	2,200	2,600
Capacity	m ³	3.00	3.50	4.00	4.50	5.00	6.00
Weight	kg	2,510	2,625	2,770	2,940	3,035	3,265
Grab model GMZ 120							
Width of shells	mm	1,600	1,800	2,000	2,200		
Capacity	m ³	4.00	4.50	5.00	5.50		
Weight	kg	3,040	3,135	3,295	3,425		



Multi-Tine Grab

open

semi-closed

closed

Grab model GMM 80-4 (4 tines)		open			semi-closed			closed		
Capacity	m ³	1.10	1.40	1.70	1.10	1.40	1.70			1.40*
Weight	kg	1,895	1,935	1,995	2,090	2,150	2,210			2,430
Grab model GMM 120-4 (4 tines)		open			semi-closed			closed		
Capacity	m ³	1.70	2.00	2.50	3.00	1.70	2.00	2.50	3.00	
Weight	kg	2,155	2,200	2,255	2,305	2,415	2,470	2,560	2,655	
Grab model GMM 80-5 (5 tines)		open			semi-closed			closed		
Capacity	m ³	1.10	1.40	1.70	1.10	1.40	1.70			1.10* 1.40* 1.70*
Weight	kg	2,170	2,220	2,290	2,390	2,465	2,540			2,440 2,580 2,740
Grab model GMM 120-5 (5 tines)		open			semi-closed			closed		
Capacity	m ³	1.70	2.00	2.50	3.00	1.70	2.00	2.50	3.00	
Weight	kg	2,485	2,540	2,610	2,675	2,785	2,850	2,965	3,085	

* heart-shaped

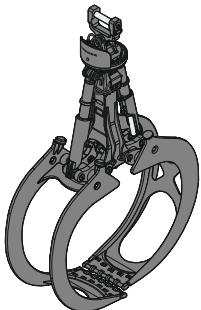

Wood Grab

Grab model GMH 80 round-shaped (complete overlapping, vertical cylinders)

Size	m ²	1.60	1.90	2.20	2.50
Cutting width	mm	870	870	870	870
Height of grab, closed	mm	2,908	2,984	3,062	3,140
Weight	kg	2,260	2,305	2,340	2,380

Grab model GMH 120 round-shaped (complete overlapping, vertical cylinders)

Size	m ²	2.80	3.20		
Cutting width	mm	870	870		
Height of grab, closed	mm	3,574	3,673		
Weight	kg	2,770	2,800		

Load Hook

Max. load	t	25
Height with suspension	mm	1,220
Weight	kg	255

Magnet Devices / Lifting Magnets

Generator	kW	20	30
Electromagnet with suspension			
Power	kW	11.7	17.8
Diameter of magnet	mm	1,500	1,700
Weight	kg	2,400*	3,300*

* only magnet plate

