



TECHNICAL SPECIFICATIONS

STATIONARY

	4200 direct	5200 direct	6200 direct	3400	5000	6000
Engine						
Power mechanical (kW):	1 x 160	1 x 200	1 x 280	-	-	-
Power hydraulic (kW):	-	-	-	1 x 160	1 x 200	1 x 280
Shredding unit						
Drum drive:	mechanical			hydraulic		
Drum rpm:	1. gear: 18 (max) 2. gear: 28 (max)	1. gear: 23 (max) 2. gear: 34 (max)	1. gear: 29 (max) 2. gear: 44 (max)	max 32	max 32	max 40
Drum length (mm):	2820					
Drum diameter (mm):	610					
Dimensions L x W x H (mm) (shredding unit incl. hopper)						
Crambo direct	8041 x 2949 x 2921					
Combined unit:	8041 x 2949 x 3191					
Separated unit:	5772 x 2949 x 3191					
Weight (dependent on equipment)						
Weight (t):	~ 18.2	~ 18.2	~ 18.2	~ 16.0	~ 16.8	~ 17.1
Throughput (dependent on material)						
Throughput performance (t/h):	up to 55	up to 80	up to 120	up to 45	up to 60	up to 100
Options						
Drum armored, hook-shaped teeth, planing teeth, bio cutting unit, screen baskets 80/100/125/150/180/250/300, soft-start, electrical control system internal/external, control panel internal/external, variants for hopper, outfeed conveyor, discharge conveyor, radio remote control, central lubrication etc.						

DIRECT (COMBINED UNIT)

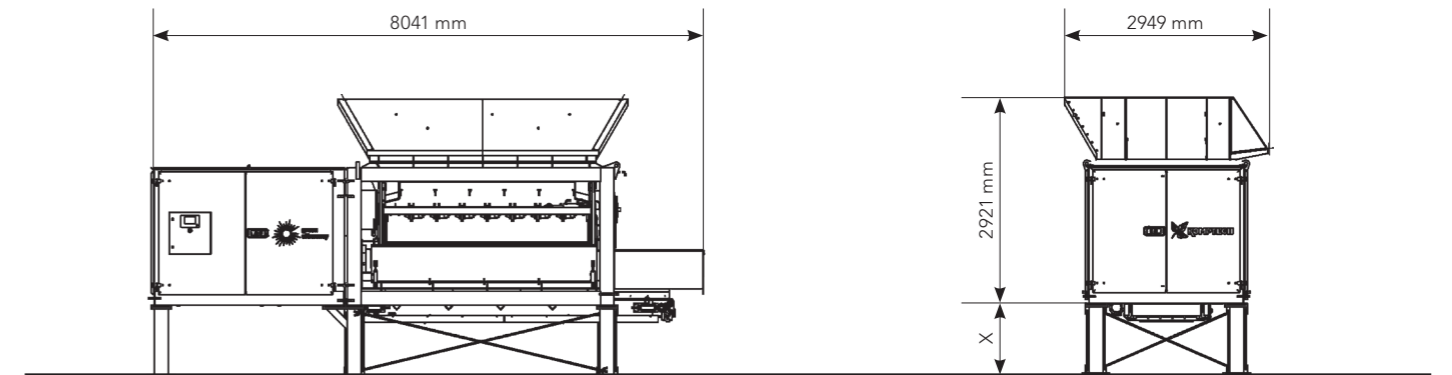

HYDRAULIC (COMBINED UNIT)

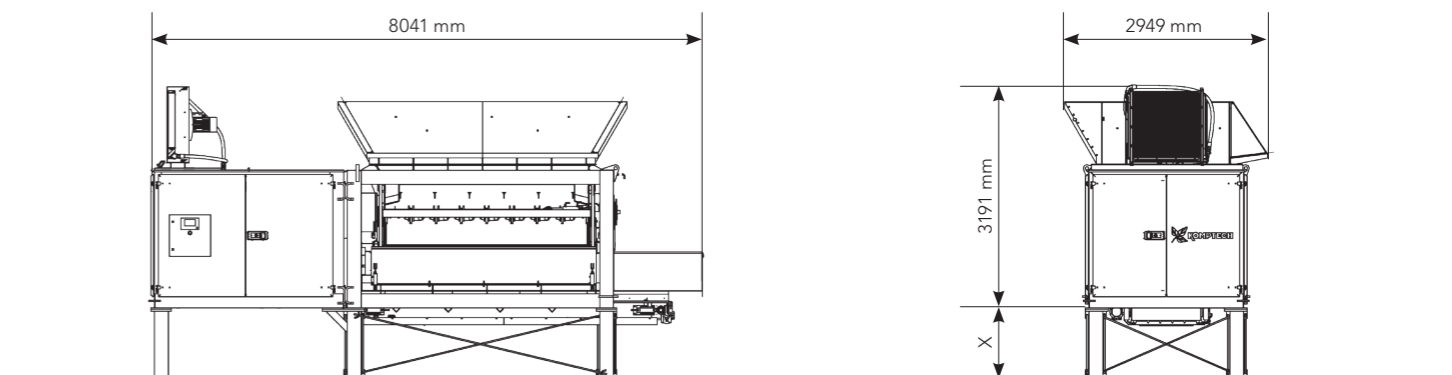

HYDRAULIC (SEPARATED UNIT)

