



TECHNICAL SPECIFICATIONS
STATIONARY

Terminator direct	1700	2200	3400	3400 S	5000 S	6000 S
Drive						
Power, mechanical (kW):	1 x 75	1 x 132	1 x 160	2 x 75	2 x 110	2 x 160
Shredding unit						
Drum rpm mobile machines:	14 / 10	17 / 13	19 / 14	14 / 10	20 / 14	28 / 20
Drum length (mm):	3000	3000	3000	3000	3000	3000
Drum diameter (mm):	1050	1050	1050	1050	1050	1050
Dimensions (shredding unit incl. hopper)						
L x W x H (mm):	5575 x 3175 x 3908					
Weight (dependent on equipment)						
Weight (t):	~ 13.6	~ 13.6	~ 14.0	~ 15.0	~ 15.3	~ 15.8
Throughput (dependent on material)						
Throughput performance (t/h):	up to 15	up to 20	up to 30	up to 35	up to 55	up to 75
Options						
Armoured drum teeth, soft-start, control panel external, variants for hopper, outfeed conveyor, discharge conveyor, remote control, central lubrication, steelwork-substructure etc.						

Terminator hydraulic	2200	3400	3400 S	5000	5000 S	6000 S
Drive						
Power, hydraulic (kW):	1 x 132	1 x 160	1 x 160	1 x 200	1 x 200	1 x 280
Shredding unit						
Drum rpm mobile machines:	29	29	27	29	29	38
Drum length (mm):	3000	3000	3000	3000	3000	3000
Drum diameter (mm):	1050	1050	1050	1050	1050	1050
Dimensions L x W x H (mm) (shredding unit incl. hopper)						
Combined unit:	8041 x 2949 x 3191					
Separated unit:	5772 x 2949 x 3191					
Weight (dependent on equipment)						
Weight (t): Combined unit	~ 15.1	~ 15.5	~ 16.5	~ 15.8	~ 16.8	~ 17.1
Throughput (dependent on material)						
Throughput performance (t/h):	up to 30	up to 45	up to 50	up to 60	up to 80	up to 100
Options						
Armoured drum teeth, soft-start, electrical control system internal/external, control panel internal/external, variants for hopper, outfeed conveyor, discharge conveyor, remote control, central lubrication, steelwork-substructure etc.						

DIRECT

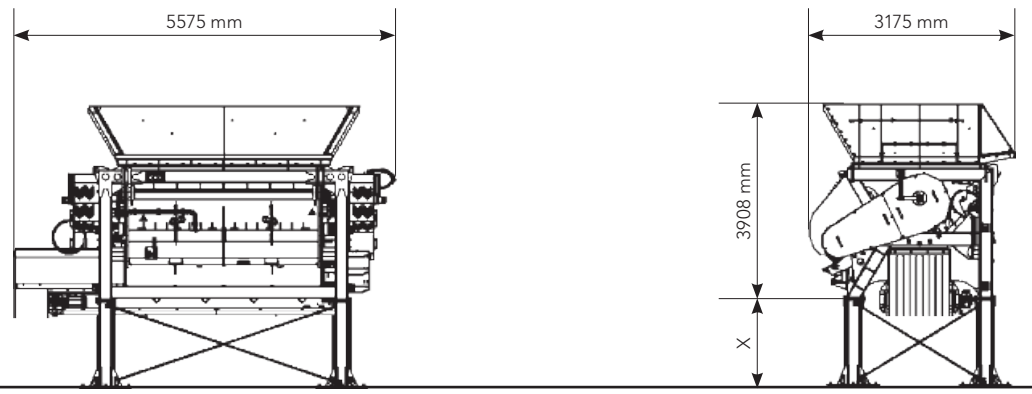

HYDRAULIC (COMBINED UNIT)

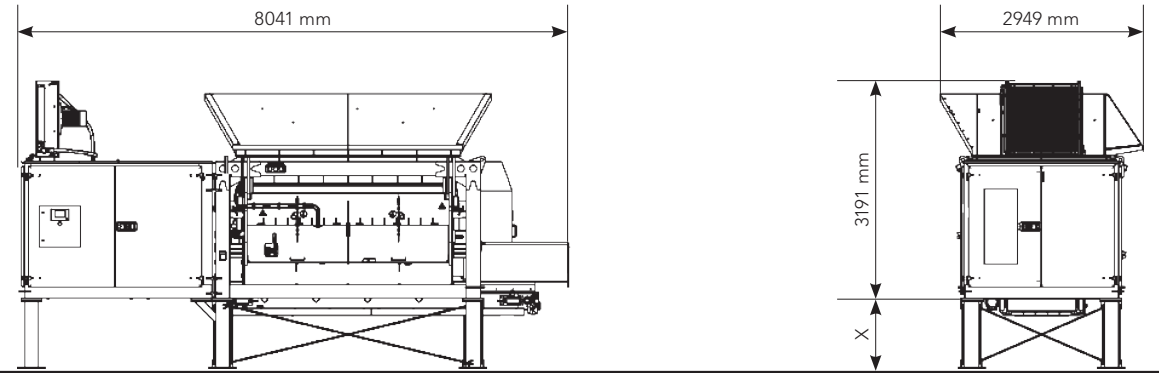

HYDRAULIC (SEPARATED UNIT)

